

SWITCHING DEVICES



ABL SURSUM offers electrical installations for industrial applications according to IEC world wide standards.

We are a traditional, family-owned company drawing on 90 years of experience in developing, producing and exporting switching devices to countries all over the globe.

Our extensive range includes MCBs, RCCBs, RCBOs, Din-Rail Products, Logic modules and Motor Protection Switches for contemporary DIN-Rail installation applications. Integrating a wide range of accessories, the ABL SURSUM system offers you the flexibility to create individual, state-of-the-art solutions. Made in Germany.

A handwritten signature in blue ink that reads "Stefan Schlutius". The signature is written in a cursive style.

Dr. Stefan Schlutius
CEO

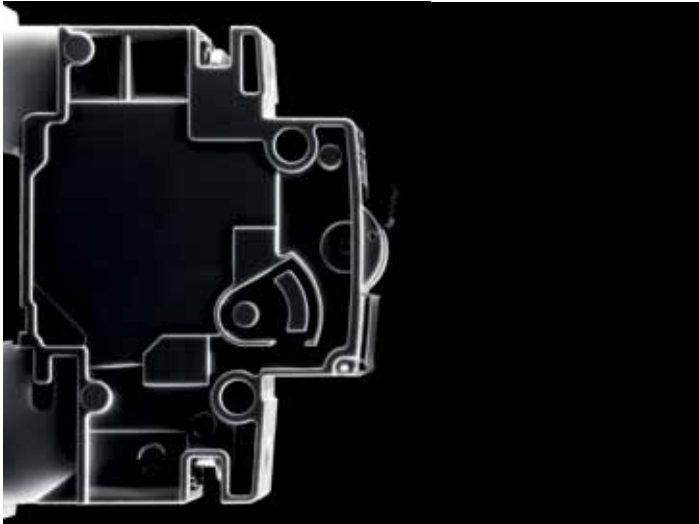

Sales organisation	6
--------------------	---

MINIATURE CIRCUIT BREAKERS	8
-----------------------------------	----------

S product range	12
SL product range	15
T product range	16
S, SL and T, Technical data	19
DC product range	28
DC, Technical data	29
S, SL, T and DC accessories	31
S, SL, T and MA busbars	33
T product range 80 A up to 125 A	35
T, Technical data 80 A up to 125 A	36
T accessories 80 A up to 125 A	37
1+N product range	38
1+N, Technical data	38
1+N busbars	39

RCCB and RCBOs	40
-----------------------	-----------

RCCB	42
RW product range	42
Sensitive to alternating currents, Type AC	42
Undelayed tripping	42
Short-time delayed tripping	45
Selective tripping	45
RP product range	46
Sensitive to pulsating currents, Type A	46
Undelayed tripping	46
Short-time delayed tripping	48
Selective tripping	48
RA product range	49
Sensitive to universal current, Type B	49
Short-time delayed tripping	49
Selective tripping	51
Auxiliary contact	53
Technical data RP und RW	54
General explanations	57
Technical features and application notes	59
RCBO	65
RC and RB product range	65
Auxiliary contact	66
Busbars	66
Technical Data	67

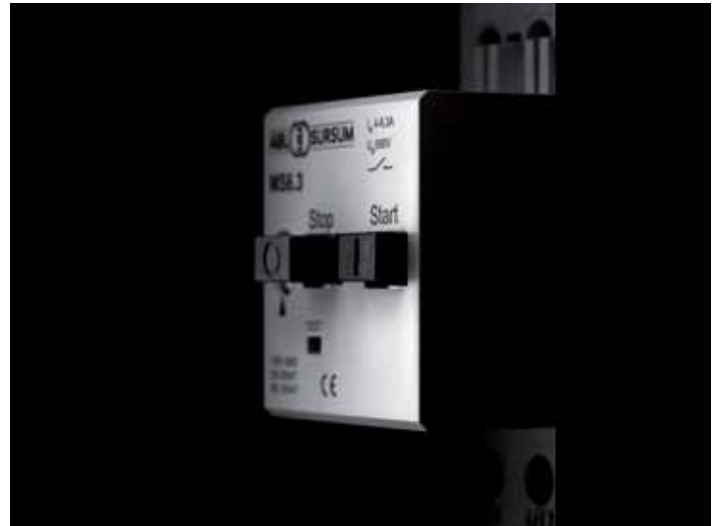

DIN-RAIL PANEL PRODUCTS

70

Switches	72
Buttons	73
Light Signals	73
SCHUKO socket outlet	73
Installation relays mechanical	74
Storage relays mechanical	74
Electronic control relays	76
Mechanical remote switches	78
Remote switch central electronic control	80
Touch dimmer	82
Load shedding relays	83
Twilight switch	84
Time relays and multi-function time relays	85
Mains monitoring	88
Installation contactors	89
Stairway light time switches	93
Synchronised / Quartz time switch	95
Digital timer	96
Transformers	97
Logic Module LoMo	98

MOTOR PROTECTIVE CIRCUIT BREAKERS

100

Motor Protective Circuit Breakers MS	102
Motor Protective Circuit Breakers MS/BS	103
Transformer Protective Circuit Breakers MST	104
Motor Protective Circuit Breakers MSH/MSW	105
Motor Protective Devices for variable-speed fan motors	106
Accessories	107
Technical Data	113
Motor Protective Circuit Breakers MA	116
Accessories	118
Busbars	118
Technical Data	120
Article Number Directory	124

SALES ORGANISATION EUROPE

AUSTRIA

Burisch Elektro-Systemtechnik
Percostraße 16
1220 Wien
T: +43 (1) 25 00 10
F: +43 (1) 2 59 97 02
office@burisch.co.at

BALTICS

Estland, Lettland, Litauen
LASD
Snikeres iela 31
LV-1067 Riga, Latvia
T: +371 67212435
mihail@lasd.lv

BELGIUM

Arfa S.P.R.L.
Rue A. Diderich 63
1060 Bruxelles
T: +32 (2) 5 39 30 54
F: +32 (2) 5 39 21 44
info@arfa.be

SES-EUPEN AG
Textilstr. 1
4700 Eupen
T: +32 (87) 85 90 50
F: +32 (87) 85 90 59
ses-eupen@ses-sterling.com

CZECH REPUBLIC

EROCOMM s.r.o.
Drevcice 141
25001 Brandys n.L.
T: +420 326 910 950
F: +420 326 914 319
info@erocomm.cz

FINLAND

Stenbacka Oy T.
Emalikatun 2 B
04440 JÄRVENPÄÄ
T: +358 (207) 432 320
F: +358 (207) 432 349
info@stenbacka.fi

FRANCE

Disimpex
14, rue Joseph Graff
67810 Holtzheim
T: +33 03 - 90 20 74 20
F: +33 03 - 88 76 90 83
info@disimpex.fr

GREECE

Christos Michelis Ltd.
Halkomatadon 8
14232 Nea Ionia/Athen
T: +30 210 2795797
F: +30 210 2724714
info@michelis-electric.gr

HUNGARY

Burisch FKT
Villanyzerel. Rendszerek
Schweidel U. 2
1047 Budapest
T: +36 1 399 - 8026
F: +36 1 369 - 5731
krisztina.schallert@burisch.hu

ICELAND

Reykjafell Ltd.
Skiptiholti 35
105 Reykjavik
T: +354 (5) 88 60 10
F: +354 (5) 88 60 88
valdi@reykjafell.is

ITALY

GSO Components s.r.l.
Via Sacco e Vanzetti, 34
20099 Sesto San Giovanni, MI
T: +39 02 244 17 534
F: +39 02 244 17 542
sales@gso-components.com

NETHERLANDS

Jacs. Koopman B. V.
Postbus 150
3960 BD Wijk bij Duurstede
T: +31 (3 43) 59 22 22
F: +31 (3 43) 59 23 33
info@jacs-koopman.nl

POLAND

ABL Polska SPz.o.o.
ul. Grzybowa 3
05-092 Lomianki
T: +48 (22) 8 68 24 59
F: +48 (22) 8 68 24 59
abl@abl-polska.pl

SLOVAKIA

EROCOMM SK s.r.o.
Koprivnická 36
84102 Bratislava
T: +421 905 940 055
F: +421 264 462 480
info@erocomm.sk

SPAIN

Coma Especialidades
Electricas
C/ Narcis Monturiol 35
08960 Sant Just Desvern
(Barcelona)
T: +34 (93) 4 90 46 24
F: +43 (93) 3 39 52 39
coma@eecomma.com

SWEDEN

L & K BJÖRKMAN
FÖRSÄLJNING AB
Malmgatan 18
60223 Norrköping
T: +46 (11) 10 53 18
F: +46 (11) 16 46 84
order@bjorkman-l-k.se

SWITZERLAND

A. Steffen AG
Limmatstr. 8
8957 Spreitenbach
T: +41 564179911
F: +41 564179910
verkauf@steffen.ch

SALES ORGANISATION WORLDWIDE

ARGENTINIA

Servicios y Suministros S.A.
Av. Boulogne Sur Mer 1947
B 1611 BWQ Don Torcuato
T: +54 11 4727 1001
F: +54 11 4727 4427
nestor.llorden@sysar.com.ar

CHINA

ABL SURSUM (Shanghai)
Co., Ltd.
Unit 653, German Centre
88 Keyuan Road, Pudong
Zhangjiang Hi-Tech Park
201203 Shanghai
T: +86 21 5080 5408, -4996
F: +86 21 5080 4956
shanghai@abl-sursum.com

EGYPT

Cairo Electrical Group
9, Rostom Street
Garden City Apt.37
Maglis EL Shaab, Cairo
T: +20 2 27961337
F: +20 2 27962719
celeg@link.com.eg

GUATEMALA

Electricidad General
13 AVE 9-44 Z.11
Colonia Roosevelt
Ciudad de Guatemala
T: +502 23877500
F: +502 23608885
info@electricidadgeneral.com

INDIA

ABL SURSUM India Pvt. Ltd.
Plot No. 52, Udyog Vihar
Phase-VI, Sector-37
122001 Gurgaon-Haryana
T: +91 1244121600
F: +91 1244121611
info@abl-sursum.com

MALAYSIA

Electech Distribution Syst.
SDN BHD 16-1, Jln. 6/89b,
Kawasan Perindustri. Trisegi,

Batu 3 1/2, Off Jln. Sungai Besi
57100 Kuala Lumpur
T: +60 3 79818950
F: +60 3 79818953
tonyteh@edsm.com.my

MOROCCO

ABL SURSUM MOROCCO S.A.
Zone Franche d'Exportation
Ilot 72 - Lot 2
MA 90000 Tanger - Maroc
T: +212 539 398000
F: +212 539 393800
alaoui@trial.ma

MEXICO

Altech Corporacion de Mexico
S de RL de CV
Santa Cruz Buenavista
Adolfo Lopez Mateos No. 1321-A
72154 Puebla, Puebla
info@altechcorp.com

MIDDLE EAST

Afghanistan, Bahrain,
Bangladesh, Brunei, Iraq, Iran,
Jordan, Qatar, Kuwait, Nepal, Oman,
Pakistan, Saudi Arabia, Syria, United
Arab Emirates
ABL SURSUM – Middle East
P.O. Box 103664
Dubai, U.A.E
T: +971 48865202
F: +971 48865203
middle.east@abl-sursum.com

NEW ZEALAND

Jackson Electrical Industries Ltd.
18-20 Gloucester Park Road
Onehunga Bay Auckland –
New Zealand
T: +64 9 6343376
F: +64 9 6340567
sales@jackson.co.nz

RUSSIA

ABL SURSUM
Dorogobuschskaya 14,
RU-121354 Moskau
russia@abl-sursum.com

SINGAPORE

ITE Electric CO Ltd.
1 Harrison Road, #01-01
ITE Electric Building
Singapore 369652
T: +65 62852233
F: +65 62843256
cseng@ite.com.sg

USA

Altech Corp.
35 Royal Road
NJ 08822-6000
T: +1 (9 08) 8 06 94 00
F: +1 (9 08) 8 06 94 90
info@altechcorp.com

VENEZUELA

EPEX C.A.
3ra Transversal c/c El Carmen
Caracas 1070 A
T: +58 212 237 3003
F: +58 212 2399341
www.kmsomerinca.com.ve

EAST EUROPE, ASIA, AUSTRALIA, NEW ZEALAND

Department head
Viktor Grünwald
T: + 49 (0)9123/188-289
F: + 49 (0)9123/188-188
viktor.gruenwald@abl-sursum.com

WEST EUROPE, NORTH AMERICA, SOUTH AMERICA, AFRICA

Department head
Klaus Schneider
T: + 49 (0)9123/188-139
F: + 49 (0)9123/188-188
klaus.schneider@abl-sursum.com



SWITCHING DEVICES

MINIATURE CIRCUIT BREAKERS

Miniature circuit breakers	
S product range	12
SL product range	15
T product range	16
S, SL and T, Technical data	19
DC product range	28
DC, Technical data	29
S, SL, T and DC accessories	31
S, SL, T and MA busbars	33
T product range 80 A up to 125 A	35
T, Technical data 80 A up to 125 A	36
T accessories 80 A up to 125 A	37
1+N product range	38
1+N, Technical data	38
1+N busbars	39

THE WINNING FEATURES OF ABL SURSUM SWITCHING DEVICES

1 FUNCTIONAL FORM

- User-friendly ergonomics
- Intuitive product coding
- Clearly marked ON/OFF positions



2 COMPACT DESIGN OFFERING MAXIMUM WIRING SPACE

At 82,5 mm height one of the smallest IEC Miniature circuit breaker available



3 EASIER BUSBAR REMOVAL

Innovative fixing slides for easy removal from the busbar, even when feeding from the top.

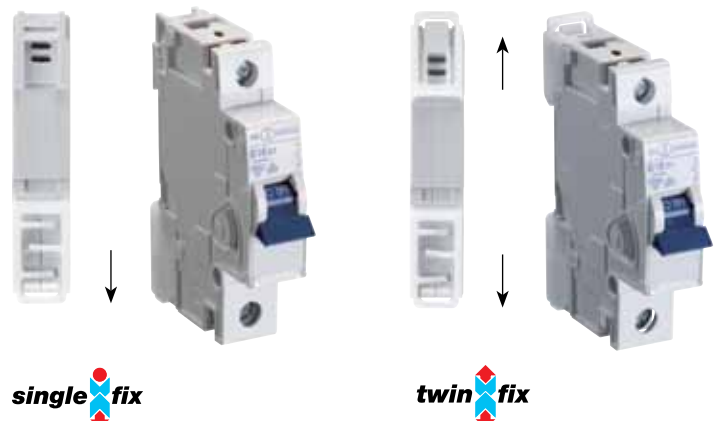

4 SWITCHING DEVICES

in a consistent and contemporary design



5 EXTENSIVE APPLICATION POSSIBILITIES

Four separate product ranges for different application in Industry and house installation in AC and DC versions. With a wide range of trip characteristics and 22 nominal ratings between 0,3 A and 63A it offers the best possible protection.

Wide range of international Certificates of approvals (VDE, Germanischer Lloyd, CCC, Gost, CEBC)

· S-Range

6kA in compliance with IEC60898
1A-63A, in B, C, Characteristic in 1-pole, 1+N, 2-pole, 3-pole, 3+N

· SL-Range

6kA in compliance with IEC60898
6A-20A, in B, C Characteristic in 1-pole and, 3-pole

· T-Range

10kA in compliance with IEC60898 and IEC 60947
0,3A-63A, in B, C, D, K, Z Characteristic in 1-pole, 1+N, 2-pole, 3-pole, 3+N, 4-pole

· DC-Range

6kA in compliance with IEC60898
0,5A-63A, in B, C, Characteristic in 1-pole, 125V and 2-pole 250V DC when serial connected

6 COMPLETE PRODUCT SYSTEM

- Full range of accessories for Circuit Breakers
- Auxilliary contacts can be mounted on the left and/or on the right side
- Common accessories for all product ranges

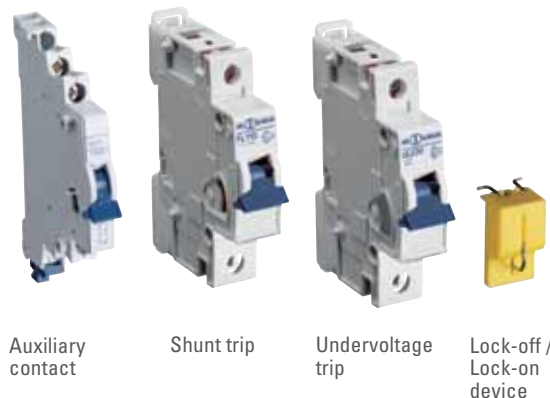

Auxiliary contact

Shunt trip

Undervoltage trip

Lock-off / Lock-on device

7 PROFESSIONAL LABELING SYSTEM

- with marking window
- Blank perforated labels available for one pole, two pole and three pole windows for convenient circuit indication



MINIATURE CIRCUIT BREAKERS S PRODUCT RANGE

6 kA B and C characteristic acc. to IEC 60898-1



6000
3

single  fix

RATED CURRENT I_n A	CHARACTERISTIC		WEIGHT g / EACH	PACKING UNIT
	B ARTICLE NO.	C ARTICLE NO.		

1-pole				
1		C1S1	120	12
2		C2S1	120	12
3		C3S1	120	12
4		C4S1	120	12
5		C5S1	120	12
6	B6S1	C6S1	120	12
10	B10S1	C10S1	120	12
13	B13S1	C13S1	120	12
16	B16S1	C16S1	120	12
20	B20S1	C20S1	120	12
25	B25S1	C25S1	120	12
32	B32S1	C32S1	120	12
40	B40S1	C40S1	125	12
50	B50S1	C50S1	135	12
63	B63S1	C63S1	135	12



6000
3

single  fix

1-pole with switched neutral				
1		C1S8	240	6
2		C2S8	240	6
3		C3S8	240	6
4		C4S8	240	6
5		C5S8	240	6
6	B6S8	C6S8	240	6
10	B10S8	C10S8	240	6
13	B13S8	C13S8	240	6
16	B16S8	C16S8	240	6
20	B20S8	C20S8	240	6
25	B25S8	C25S8	240	6
32	B32S8	C32S8	240	6
40	B40S8	C40S8	250	6
50	B50S8	C50S8	270	6
63	B63S8	C63S8	270	6

MINIATURE CIRCUIT BREAKERS S PRODUCT RANGE

6 kA B and C characteristic acc. to IEC 60898-1



6000
3

single fix

RATED CURRENT I_n A	CHARACTERISTIC		WEIGHT g / EACH	PACKING UNIT
	B ARTICLE NO.	C ARTICLE NO.		

2-pole				
1		C1S2	240	6
2		C2S2	240	6
3		C3S2	240	6
4		C4S2	240	6
5		C5S2	240	6
6	B6S2	C6S2	240	6
10	B10S2	C10S2	240	6
13	B13S2	C13S2	240	6
16	B16S2	C16S2	240	6
20	B20S2	C20S2	240	6
25	B25S2	C25S2	240	6
32	B32S2	C32S2	240	6
40	B40S2	C40S2	250	6
50	B50S2	C50S2	270	6
63	B63S2	C63S2	270	6



6000
3

single fix

3-pole				
1		C1S3	360	4
2		C2S3	360	4
3		C3S3	360	4
4		C4S3	360	4
5		C5S3	360	4
6	B6S3	C6S3	360	4
10	B10S3	C10S3	360	4
13	B13S3	C13S3	360	4
16	B16S3	C16S3	360	4
20	B20S3	C20S3	360	4
25	B25S3	C25S3	360	4
32	B32S3	C32S3	360	4
40	B40S3	C40S3	375	4
50	B50S3	C50S3	405	4
63	B63S3	C63S3	405	4

MINIATURE CIRCUIT BREAKERS S PRODUCT RANGE

6 kA B and C characteristic acc. to IEC 60898-1



6000
3

single  fix

RATED CURRENT I_n A	CHARACTERISTIC		WEIGHT g / EACH	PACKING UNIT
	B ARTICLE NO.	C ARTICLE NO.		

3-pole with switched neutral				
1		C1S9	480	3
2		C2S9	480	3
3		C3S9	480	3
4		C4S9	480	3
5		C5S9	480	3
6	B6S9	C6S9	480	3
10	B10S9	C10S9	480	3
13	B13S9	C13S9	480	3
16	B16S9	C16S9	480	3
20	B20S9	C20S9	480	3
25	B25S9	C25S9	480	3
32	B32S9	C32S9	480	3
40	B40S9	C40S9	500	3
50	B50S9	C50S9	540	3
63	B63S9	C63S9	540	3

MINIATURE CIRCUIT BREAKERS SL PRODUCT RANGE

With screwless top terminal · 6 kA B and C characteristic acc. to IEC 60898-1



RATED CURRENT I_n A	CHARACTERISTIC		WEIGHT g / EACH	PACKING UNIT
	B ARTICLE NO.	C ARTICLE NO.		

1-pole				
6	B6SL1	C6SL1	120	12
10	B10SL1	C10SL1	120	12
13	B13SL1	C13SL1	120	12
16	B16SL1	C16SL1	120	12
20	B20SL1	C20SL1	120	12



6000
3

plug  power



3-pole				
6	B6SL3	C6SL3	360	4
10	B10SL3	C10SL3	360	4
13	B13SL3	C13SL3	360	4
16	B16SL3	C16SL3	360	4
20	B20SL3	C20SL3	360	4



6000
3

plug  power

MINIATURE CIRCUIT BREAKERS T PRODUCT RANGE

10 kA B, C and D characteristic acc. to IEC 60898-1

10 kA K and Z characteristic acc. to IEC 60947-2

This product range differentiates between:

- Standard products (**shown in the table in bold**)
- Special products (shown in the table in normal print – longer delivery time)



RATED CURRENT I_n A	CHARACTERISTIC					WEIGHT g/EACH	PACKING UNIT
	B ARTICLE NO.	C ARTICLE NO.	D ARTICLE NO.	K ARTICLE NO.	Z ARTICLE NO.		

1-pole							
0.3		C0.3T1	D0.3T1	K0.3T1	Z0.3T1	120	12
0.5		C0.5T1	D0.5T1	K0.5T1	Z0.5T1	120	12
0.8		C0.8T1	D0.8T1	K0.8T1	Z0.8T1	120	12
1	B1T1	C1T1	D1T1	K1T1	Z1T1	120	12
1.6		C1.6T1	D1.6T1	K1.6T1	Z1.6T1	120	12
2	B2T1	C2T1	D2T1	K2T1	Z2T1	120	12
2.5		C2.5T1	D2.5T1	K2.5T1	Z2.5T1	120	12
3	B3T1	C3T1	D3T1	K3T1	Z3T1	120	12
3.5		C3.5T1	D3.5T1	K3.5T1	Z3.5T1	120	12
4	B4T1	C4T1	D4T1	K4T1	Z4T1	120	12
5	B5T1	C5T1	D5T1	K5T1	Z5T1	120	12
6	B6T1	C6T1	D6T1	K6T1	Z6T1	120	12
8		C8T1	D8T1	K8T1	Z8T1	120	12
10	B10T1	C10T1	D10T1	K10T1	Z10T1	120	12
13	B13T1	C13T1	D13T1	K13T1	Z13T1	120	12
16	B16T1	C16T1	D16T1	K16T1	Z16T1	120	12
20	B20T1	C20T1	D20T1	K20T1	Z20T1	120	12
25	B25T1	C25T1	D25T1	K25T1	Z25T1	120	12
32	B32T1	C32T1	D32T1	K32T1	Z32T1	120	12
40	B40T1	C40T1	D40T1	K40T1		125	12
50	B50T1	C50T1	D50T1 *	K50T1		135	12
63	B63T1	C63T1	D63T1 *	K63T1		135	12



1-pole with switched neutral							
0.3		C0.3T8	D0.3T8	K0.3T8		240	6
0.5		C0.5T8	D0.5T8	K0.5T8		240	6
0.8		C0.8T8	D0.8T8	K0.8T8		240	6
1	B1T8	C1T8	D1T8	K1T8		240	6
1.6		C1.6T8	D1.6T8	K1.6T8		240	6
2	B2T8	C2T8	D2T8	K2T8		240	6
2.5		C2.5T8	D2.5T8	K2.5T8		240	6
3	B3T8	C3T8	D3T8	K3T8		240	6
3.5		C3.5T8	D3.5T8	K3.5T8		240	6
4	B4T8	C4T8	D4T8	K4T8		240	6
5	B5T8	C5T8	D5T8	K5T8		240	6
6	B6T8	C6T8	D6T8	K6T8		240	6
8		C8T8	D8T8	K8T8		240	6
10	B10T8	C10T8	D10T8	K10T8		240	6
13	B13T8	C13T8	D13T8	K13T8		240	6
16	B16T8	C16T8	D16T8	K16T8		240	6
20	B20T8	C20T8	D20T8	K20T8		240	6
25	B25T8	C25T8	D25T8	K25T8		240	6
32	B32T8	C32T8	D32T8	K32T8		240	6
40	B40T8	C40T8	D40T8	K40T8		250	6
50	B50T8	C50T8	D50T8 *	K50T8		270	6
63	B63T8	C63T8	D63T8 *	K63T8		270	6

* 10 kA acc. to IEC 60947-2

MINIATURE CIRCUIT BREAKERS T PRODUCT RANGE

10 kA B, C and D characteristic acc. to IEC 60898-1

10 kA K and Z characteristic acc. to IEC 60947-2

This product range differentiates between:

- Standard products (**shown in the table in bold**)
- Special products (shown in the table in normal print – longer delivery time)

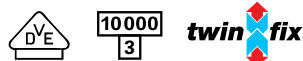

RATED CURRENT I_n A	CHARACTERISTIC					WEIGHT g/EACH	PACKING UNIT
	B ARTICLE NO.	C ARTICLE NO.	D ARTICLE NO.	K ARTICLE NO.	Z ARTICLE NO.		

2-pole							
0.3		C0.3T2	D0.3T2	K0.3T2	Z0.3T2	240	6
0.5		C0.5T2	D0.5T2	K0.5T2	Z0.5T2	240	6
0.8		C0.8T2	D0.8T2	K0.8T2	Z0.8T2	240	6
1	B1T2	C1T2	D1T2	K1T2	Z1T2	240	6
1.6		C1.6T2	D1.6T2	K1.6T2	Z1.6T2	240	6
2	B2T2	C2T2	D2T2	K2T2	Z2T2	240	6
2.5		C2.5T2	D2.5T2	K2.5T2	Z2.5T2	240	6
3	B3T2	C3T2	D3T2	K3T2	Z3T2	240	6
3.5		C3.5T2	D3.5T2	K3.5T2	Z3.5T2	240	6
4	B4T2	C4T2	D4T2	K4T2	Z4T2	240	6
5	B5T2	C5T2	D5T2	K5T2	Z5T2	240	6
6	B6T2	C6T2	D6T2	K6T2	Z6T2	240	6
8		C8T2	D8T2	K8T2	Z8T2	240	6
10	B10T2	C10T2	D10T2	K10T2	Z10T2	240	6
13	B13T2	C13T2	D13T2	K13T2	Z13T2	240	6
16	B16T2	C16T2	D16T2	K16T2	Z16T2	240	6
20	B20T2	C20T2	D20T2	K20T2	Z20T2	240	6
25	B25T2	C25T2	D25T2	K25T2	Z25T2	240	6
32	B32T2	C32T2	D32T2	K32T2	Z32T2	240	6
40	B40T2	C40T2	D40T2	K40T2		250	6
50	B50T2	C50T2	D50T2 *	K50T2		270	6
63	B63T2	C63T2	D63T2 *	K63T2		270	6

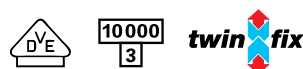

3-pole							
0.3		C0.3T3	D0.3T3	K0.3T3	Z0.3T3	360	4
0.5		C0.5T3	D0.5T3	K0.5T3	Z0.5T3	360	4
0.8		C0.8T3	D0.8T3	K0.8T3	Z0.8T3	360	4
1	B1T3	C1T3	D1T3	K1T3	Z1T3	360	4
1.6		C1.6T3	D1.6T3	K1.6T3	Z1.6T3	360	4
2	B2T3	C2T3	D2T3	K2T3	Z2T3	360	4
2.5		C2.5T3	D2.5T3	K2.5T3	Z2.5T3	360	4
3	B3T3	C3T3	D3T3	K3T3	Z3T3	360	4
3.5		C3.5T3	D3.5T3	K3.5T3	Z3.5T3	360	4
4	B4T3	C4T3	D4T3	K4T3	Z4T3	360	4
5	B5T3	C5T3	D5T3	K5T3	Z5T3	360	4
6	B6T3	C6T3	D6T3	K6T3	Z6T3	360	4
8		C8T3	D8T3	K8T3	Z8T3	360	4
10	B10T3	C10T3	D10T3	K10T3	Z10T3	360	4
13	B13T3	C13T3	D13T3	K13T3	Z13T3	360	4
16	B16T3	C16T3	D16T3	K16T3	Z16T3	360	4
20	B20T3	C20T3	D20T3	K20T3	Z20T3	360	4
25	B25T3	C25T3	D25T3	K25T3	Z25T3	360	4
32	B32T3	C32T3	D32T3	K32T3	Z32T3	360	4
40	B40T3	C40T3	D40T3	K40T3		375	4
50	B50T3	C50T3	D50T3 *	K50T3		405	4
63	B63T3	C63T3	D63T3 *	K63T3		405	4

* 10 kA acc. to IEC 60947-2

MINIATURE CIRCUIT BREAKERS T PRODUCT RANGE

10 kA B, C and D characteristic acc. to IEC 60898-1

10 kA K and Z characteristic acc. to IEC 60947-2

This product range differentiates between:

- Standard products (**shown in the table in bold**)
- Special products (shown in the table in normal print – longer delivery time)

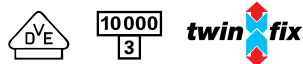

RATED CURRENT I_n A	CHARACTERISTIC					WEIGHT g/EACH	PACKING UNIT
	B ARTICLE NO.	C ARTICLE NO.	D ARTICLE NO.	K ARTICLE NO.	Z ARTICLE NO.		

3-pole with switched neutral							
0.3		C0.3T9	D0.3T9	K0.3T9		480	3
0.5		C0.5T9	D0.5T9	K0.5T9		480	3
0.8		C0.8T9	D0.8T9	K0.8T9		480	3
1	B1T9	C1T9	D1T9	K1T9		480	3
1.6		C1.6T9	D1.6T9	K1.6T9		480	3
2	B2T9	C2T9	D2T9	K2T9		480	3
2.5		C2.5T9	D2.5T9	K2.5T9		480	3
3	B3T9	C3T9	D3T9	K3T9		480	3
3.5		C3.5T9	D3.5T9	K3.5T9		480	3
4	B4T9	C4T9	D4T9	K4T9		480	3
5	B5T9	C5T9	D5T9	K5T9		480	3
6	B6T9	C6T9	D6T9	K6T9		480	3
8		C8T9	D8T9	K8T9		480	3
10	B10T9	C10T9	D10T9	K10T9		480	3
13	B13T9	C13T9	D13T9	K13T9		480	3
16	B16T9	C16T9	D16T9	K16T9		480	3
20	B20T9	C20T9	D20T9	K20T9		480	3
25	B25T9	C25T9	D25T9	K25T9		480	3
32	B32T9	C32T9	D32T9	K32T9		480	3
40	B40T9	C40T9	D40T9	K40T9		500	3
50	B50T9	C50T9	D50T9 *	K50T9		540	3
63	B63T9	C63T9	D63T9 *	K63T9		540	3

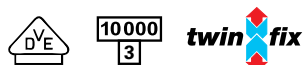

4-pole							
0.3		C0.3T4	D0.3T4	K0.3T4		480	3
0.5		C0.5T4	D0.5T4	K0.5T4		480	3
0.8		C0.8T4	D0.8T4	K0.8T4		480	3
1	B1T4	C1T4	D1T4	K1T4		480	3
1.6		C1.6T4	D1.6T4	K1.6T4		480	3
2	B2T4	C2T4	D2T4	K2T4		480	3
2.5		C2.5T4	D2.5T4	K2.5T4		480	3
3	B3T4	C3T4	D3T4	K3T4		480	3
3.5		C3.5T4	D3.5T4	K3.5T4		480	3
4	B4T4	C4T4	D4T4	K4T4		480	3
5	B5T4	C5T4	D5T4	K5T4		480	3
6	B6T4	C6T4	D6T4	K6T4		480	3
8		C8T4	D8T4	K8T4		480	3
10	B10T4	C10T4	D10T4	K10T4		480	3
13	B13T4	C13T4	D13T4	K13T4		480	3
16	B16T4	C16T4	D16T4	K16T4		480	3
20	B20T4	C20T4	D20T4	K20T4		480	3
25	B25T4	C25T4	D25T4	K25T4		480	3
32	B32T4	C32T4	D32T4	K32T4		480	3
40	B40T4	C40T4	D40T4	K40T4		500	3
50	B50T4	C50T4	D50T4 *	K50T4		540	3
63	B63T4	C63T4	D63T4 *	K63T4		540	3

* 10 kA acc. to IEC 60947-2

MINIATURE CIRCUIT BREAKERS S, SL AND T PRODUCT RANGES

Technical Data

Characteristic	B	C	D	K	Z
Application	Wiring protection	Wiring protection Device protection	Wiring protection Power circuits Transformers Motors	Wiring protection Power circuits Transformers Motors	Wiring protection Semiconductor protection High impedance
Number of poles					
Product range „S“	1-3; 1+N; 3+N		-	-	-
Product range „SL“	1 and 3		-	-	-
Product range „T“	1 - 4; 1 + N; 3 + N				1 - 3
Standards short circuit withstand rating	IEC 60898-1, DIN EN 60898-1, VDE 0641-11			IEC 60947-2, DIN EN 60947-2, VDE 0660-101	
Product range „S“	6 kA	6 kA	-	-	-
Product range „SL“	6 kA	6 kA	-	-	-
Product range „T“	10 kA	10 kA	10 kA	10 kA	10 kA
Current limiting class	3	3			
Max. back-up fuse	Fuse according to DIN VDE 0636 125 A operating class gL/gG				
Rated AC voltage	230 / 400 V				
Rated DC voltage L/R = 4 ms	1-pole 60 V, 2-pole 125 V in serial connection of both poles				
Rated current range I _n					
Product range „S“	6 - 63 A	1 - 63 A	-	-	-
Product range „SL“	6 - 20 A	6 - 20 A	-	-	-
Product range „T“	1 - 63 A	0.3 - 63 A	0,3 - 63 A	0.3 - 63 A	0.3 - 32 A
Test currents	Thermal not tripping I ₁ (A) > 1 h	1.13 x I _n	1.13 x I _n	1.13 x I _n	1.05 x I _n
	Thermal tripping I ₂ (A) < 1 h	1.45 x I _n	1.45 x I _n	1.45 x I _n	1.2 x I _n
	Electromagnetic not tripping I ₄ (A) > 0,1 s	3 x I _n	5 x I _n	10 x I _n	8 x I _n
	Electromagnetic tripping I ₅ (A) < 0,1 s	5 x I _n	10 x I _n	20 x I _n	12 x I _n
Reference calibration temperature of the thermal tripping	30°C + 5°C			20°C + 5°C	
	Influence of the ambient temperature on the thermal tripping: Decrease of the current values with higher ambient temperature and increase with lower temperatures of approximately 5% per 10°C difference in temperature				
Frequency range of the electromagnetic trip	16 ² / ₃ to 60 Hz With higher frequencies, the electromagnetic tripping values increase by approximately a factor of 1.1 at 100 Hz; 1.2 at 200 Hz; 1.3 at 300 Hz; 1.4 at 400 Hz; 1.5 for DC				
Ambient temperature	-25°C to +55°C				
Storage temperature	-40°C to +70°C				
Device depth acc. to DIN 43880	68 mm				
Mechanical endurance	20,000 switching cycles (20,000 ON / 20,000 OFF)				
Protection cover	Finger safe and safe to back of hand according to DIN EN 50274/VDE0660-514, BGV A3				
Insulation group according to DIN VDE 0110	C at 250 V AC B at 400 V AC				
Degree of protection according to EN / IEC 60529	IP20				
Installation position	any				
Mounting	DIN-rail according to DIN EN 60715 35 mm				
Lockability	The handle can be secured against manual switching in the on and off position by a lead seal				
Climatic resistance	Humid heat constant according to DIN IEC 60068-2-78 Humid heat cycle according to DIN EN 60068-2-30				
Vibration resistance	> 15 g according to DIN EN 60068-2-59 during a load with I ₁				
Resistance to mechanical shocks	25g 11ms				

MINIATURE CIRCUIT BREAKERS S, SL AND T PRODUCT RANGES

Technical Data

Additional performance features of the T product range – short circuit withstand rating according to IEC 60947-2, DIN EN 60947-2			
Characteristic	B, C, D, K, Z		
1-pole	0.3 - 40 A	254/440 V	10 kA
2-pole / 3-pole	0.3 - 40 A	440 V	10 kA
Characteristic	B, C		
1-pole	0.3 - 20 A	230/400 V	20 kA

Conductor cross sections product ranges S and T				
Type of conductor *)	Box terminal bottom		Box terminal top	
	max.	min.	max.	min.
Single wire	35 mm ²	0.5 mm ²	25 mm ²	0.5 mm ²
Multiple wire	35 mm ²	1.5 mm ²	25 mm ²	1.5 mm ²
Stranded wire	25 mm ²	1 mm ²	16 mm ²	1 mm ²
Stranded wire with ferrule	16 mm ²	0.5 mm ²	16 mm ²	0.5 mm ²
Busbar cable lug	Up to 3 mm thickness		Up to 3 mm thickness	
Combined, conductor and busbar or cable lug	Up to 35 mm ² and up to 2 mm thickness		Up to 25 mm ² and up to 2 mm thickness	
Torque	max. 2.5 Nm			

Conductor cross sections SL product range				
Type of conductor *)	Box terminal bottom		Screwless terminal top	
	max.	min.	max.	min.
Single wire	35 mm ²	0.5 mm ²	4 mm ²	1 mm ²
Multiple wire	35 mm ²	1.5 mm ²	4 mm ²	1.5 mm ²
Stranded wire	25 mm ²	1 mm ²	4 mm ²	1 mm ²
Stranded wire with ferrule	16 mm ²	0.5 mm ²	2.5 mm ²	1 mm ²
Busbar cable lug	Up to 3 mm thickness		-	
Combined, conductor and busbar or cable lug	Up to 35 mm ² and up to 2 mm thickness		-	
Torque	max. 2.5 Nm			

*) Stripped length 12–14 mm

The following characteristics can be chosen:

- B characteristic for wiring protection
- C characteristic for device protection with higher starting current inrush
- D characteristic for the protection of power circuits, motors and transformers
- K characteristic for the protection of power circuits, motors and transformers
- Z characteristic for semiconductor protection at high impedances

No. of Poles	S Range					SL Range		T Range					
	1	2	3	1+N	3+N	1	3	1	2	3	4	1+N	3+N
B-characteristic	•	•	•	•	•	•	•	•	•	•	•	•	•
C-characteristic	•	•	•	•	•	•	•	•	•	•	•	•	•
D-characteristic								•	•	•	•	•	•
K-characteristic								•	•	•	•	•	•
Z-characteristic								•	•	•	•		
	↓					↓		↓					
	Standard products					Standard products		Special products					

MINIATURE CIRCUIT BREAKERS S, SL AND T PRODUCT RANGES

Dimension Drawings

Miniature circuit breakers, **S** product range

- with screw terminals

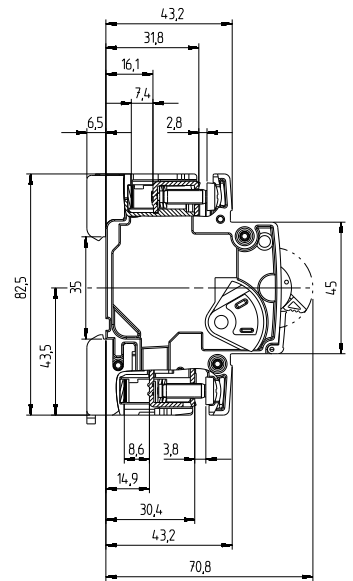
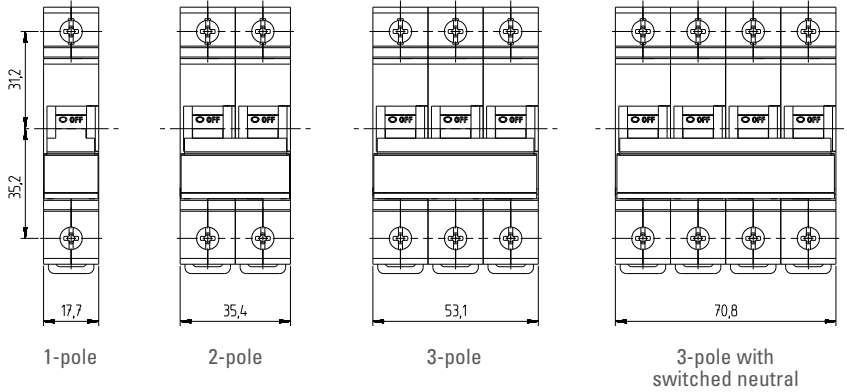

Miniature circuit breakers, **SL** product range

- with screwless terminals

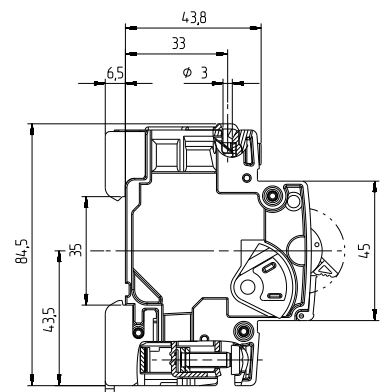
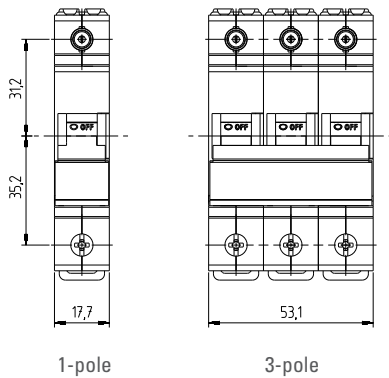

Miniature circuit breakers, **T** product range

- with screw terminals

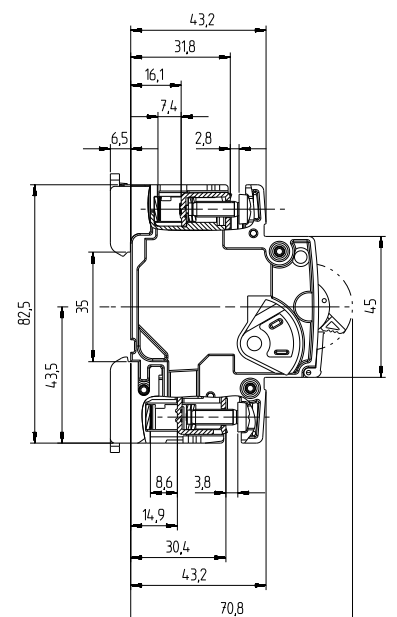
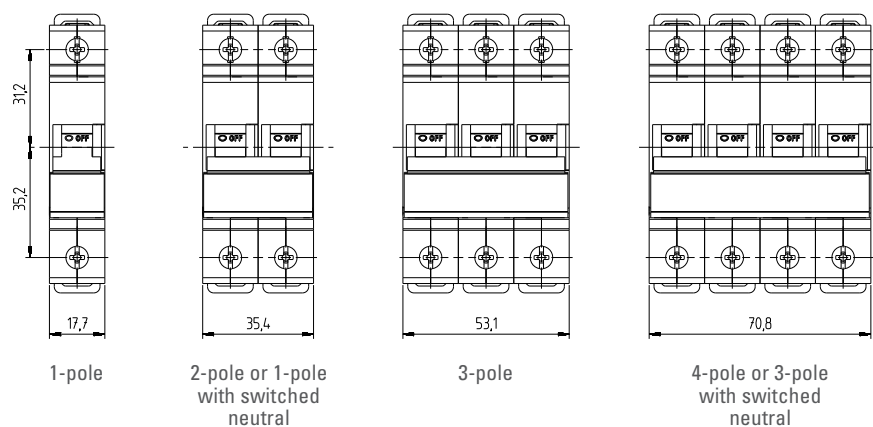

MINIATURE CIRCUIT BREAKERS S, SL AND T PRODUCT RANGES

Characteristic acc. to IEC 60898-1

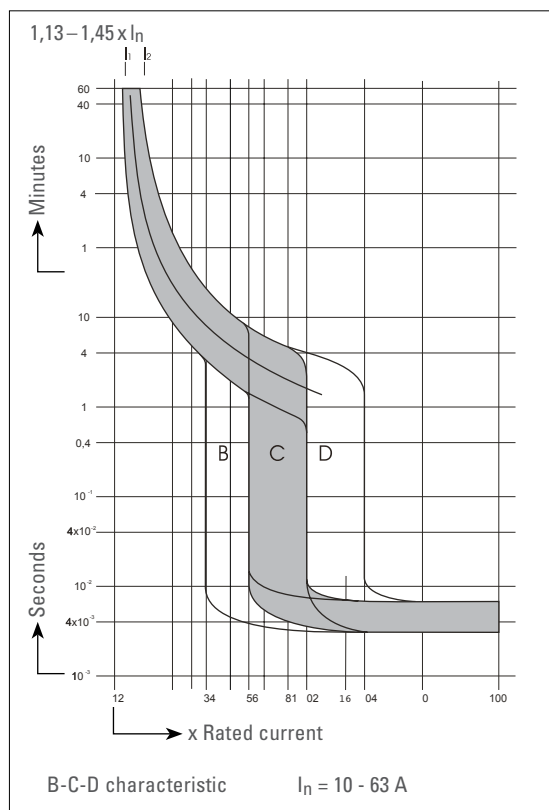
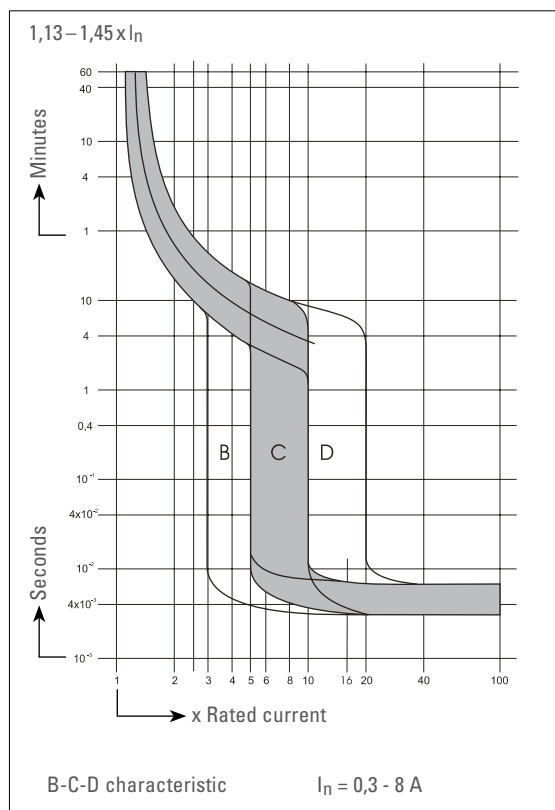

Delayed thermal overload tripping

- I_n = Rated current**
Current which the miniature circuit breaker can sustain in uninterrupted operation
- I_b = Rated operational current**
Current determined by the load during undisturbed operation
- I_1 = Thermal not tripping current**
Current which, under defined conditions, does not lead to switching off within 60 min
- I_2 = Thermal tripping current**
Current which, under defined conditions, leads to switching off within 60 min
- I_1 zu I_2 = Conditions**
Current which, under defined conditions, is run up from I_1 to I_2 with a continuous increase, and leads to switch off within 60 min
- I_3 = Tolerance limitation**
at 2.55-times the rated current / nominal current
Current which, under defined conditions, does not lead to switch off within 1 sec
Current which, under defined conditions, leads to switch off at rated currents up to 32 A within 60 sec, at rated currents above 32 A within 120 sec

Undelayed electromagnetic short circuit tripping

- I_4 = Magnetic not tripping current**
Current which, under defined conditions, does not lead to switching off within 0.1 sec
- I_5 = Magnetic tripping current**
Current which, under defined conditions, leads to switching off within 0.1 sec

Dependence of the short circuit trip at higher frequencies and for direct current.

- at 100 Hz about 1.1 times
- at 200 Hz about 1.2 times
- at 300 Hz about 1.3 times
- at 400 Hz about 1.4 times
- at 500 Hz about 1.5 times
- for DC about 1.5 times

MINIATURE CIRCUIT BREAKERS T PRODUCT RANGE

Characteristic acc. to IEC 60947-2

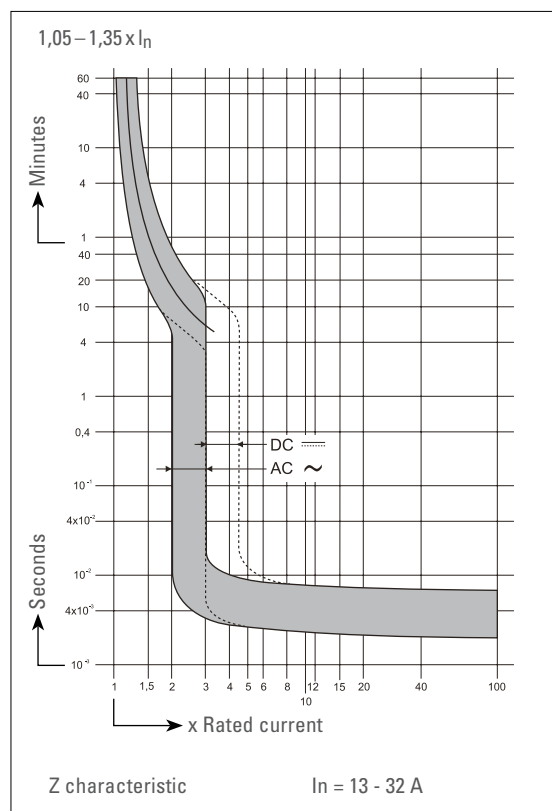
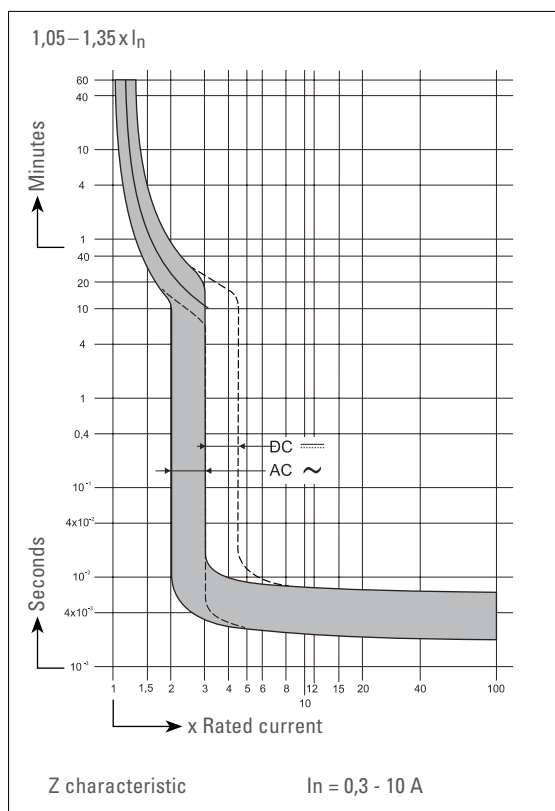
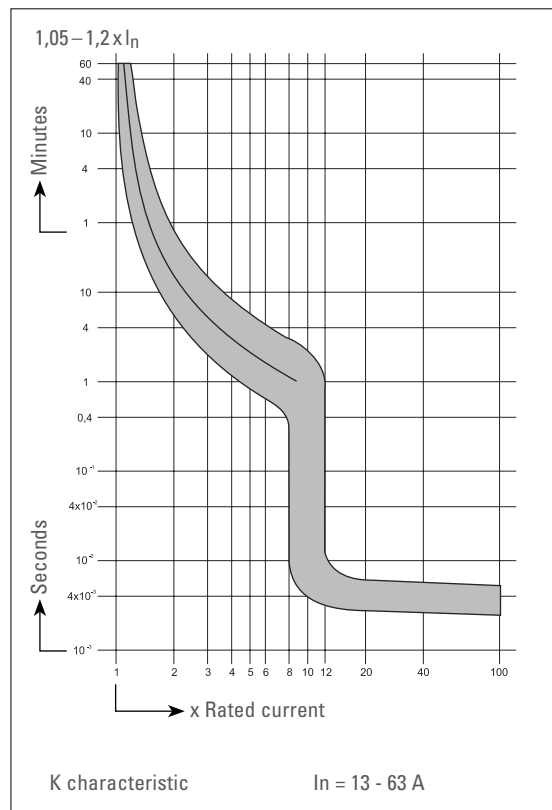
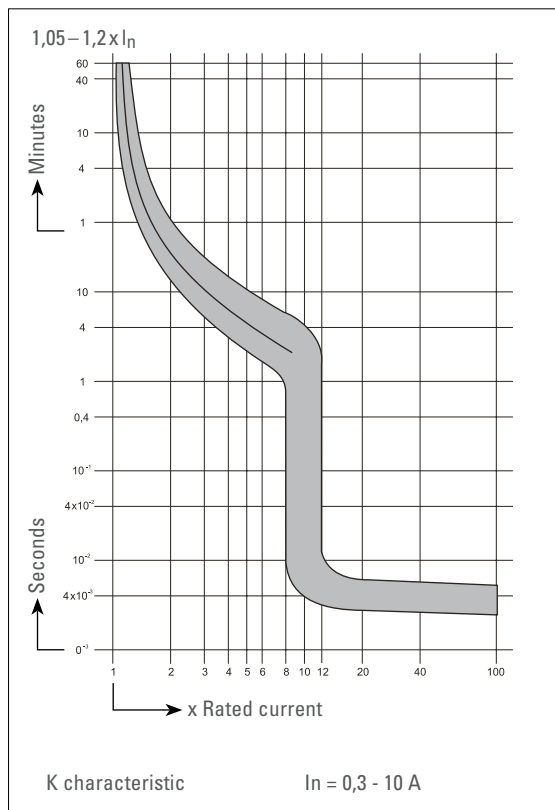

MINIATURE CIRCUIT BREAKERS S, SL AND T PRODUCT RANGES

Technical Data

Internal resistances in mOhm and power losses in Watt per pole (at I_n)

RATED CURRENT I _n (A)	B-CHARACTERISTIC		C-CHARACTERISTIC		D-CHARACTERISTIC		K-CHARACTERISTIC		Z-CHARACTERISTIC	
	INTERNAL RESISTANCE mOhm	POWER LOSS Watt	INTERNAL RESISTANCE mOhm.	POWER LOSS Watt	INTERNAL RESISTANCE mOhm.	POWER LOSS Watt	INTERNAL RESISTANCE mOhm.	POWER LOSS Watt	INTERNAL RESISTANCE mOhm.	POWER LOSS Watt
0,3	-	-	16600	1,5	16600,0	1,5	16860,0	1,5	31500,0	2,8
0,5	-	-	6850	1,7	6850,0	1,7	6850,0	1,7	10250,0	2,6
0,8	-	-	3050	2,0	3050,0	2,0	3050,0	2,0	5150,0	3,3
1	1950	2,0	1750	1,8	1750,0	1,8	1750,0	1,8	2690,0	2,7
1,6	-	-	590	1,5	590,0	1,5	590,0	1,5	940,0	2,4
2	510	2,0	420	1,7	420,0	1,7	420,0	1,7	690,0	2,8
2,5	-	-	295	1,8	295,0	1,8	295,0	1,8	430,0	2,7
3	211	1,9	200	1,8	173,0	1,6	200,0	1,8	345,0	3,1
3,5	-	-	125	1,5	125,0	1,5	125,0	1,5	225,0	2,8
4	131	2,1	109	1,7	105,0	1,7	109,0	1,7	225,0	3,6
5	85	2,1	61,6	1,5	61,6	1,5	65,4	1,6	105,0	2,6
6	52,9	1,9	49,1	1,8	45,9	1,7	49,1	1,8	82,3	3,0
8	-	-	24	1,5	20,7	1,3	44,0	2,8	37,1	2,4
10	13,4	1,3	13,4	1,3	13,4	1,3	31,5	3,1	27,8	2,8
13	11,3	1,9	8,04	1,4	8,1	1,4	8,8	1,5	15,1	2,6
16	8,04	2,1	8,04	2,1	8,1	2,1	7,5	1,9	11,3	2,9
20	7,1	2,8	7,45	3,0	6,4	2,5	6,3	2,5	7,4	3,0
25	5	3,1	5	3,1	4,1	2,5	4,7	2,9	5,8	3,7
32	3,6	3,7	3,6	3,7	2,7	2,8	2,8	2,9	3,6	3,7
40	2,2	3,5	2,2	3,5	2,2	3,5	2,2	3,5	-	-
50	1,95	4,9	1,9	4,8	1,8	4,6	2,0	4,9	-	-
63	1,77	7,0	1,77	7,0	1,7	6,8	1,8	7,0	-	-

Overload and short circuit currents

I _n (A)	OVERLOAD						SHORT CIRCUIT									
	B, C, D		K		Z		B		C		D		K		Z	
	I ₁	I ₂	I ₁	I ₂	I ₁	I ₂	I ₄	I ₅	I ₄	I ₅	I ₄	I ₅	I ₄	I ₅	I ₄	I ₅
1,13	1,45	1,05	1,2	1,05	1,35	3	5	5	10	10	20	8	12	2	3	
0,3	0,339	0,435	0,315	0,360	0,315	0,405	-	-	1,5	3	3	6	2,4	3,6	0,6	0,9
0,5	0,565	0,725	0,525	0,600	0,525	0,675	-	-	2,5	5	5	10	4	6	1	1,5
0,75	0,848	1,088	0,788	0,900	0,788	1,013	-	-	3,75	7,5	7,5	15	6	9	1,5	2,25
1	1,13	1,45	1,05	1,20	1,05	1,35	3	5	5	10	10	20	8	12	2	3
1,6	1,81	2,32	1,68	1,92	1,68	2,16	-	-	8	16	16	32	12,8	19,2	3,2	4,8
2	2,26	2,90	2,10	2,40	2,10	2,70	6	10	10	20	20	40	16	24	4	6
2,5	2,83	3,63	2,63	3,00	2,63	3,38	-	-	12,5	25	25	50	20	30	5	7,5
3	3,39	4,35	3,15	3,60	3,15	4,05	9	15	15	30	30	60	24	36	6	9
3,5	3,96	5,08	3,68	4,20	3,68	4,73	-	-	17,5	35	35	70	28	42	7	10,5
4	4,52	5,80	4,20	4,80	4,20	5,40	12	20	20	40	40	80	32	48	8	12
5	5,65	7,25	5,25	6,00	5,25	6,75	15	25	25	50	50	100	40	60	10	15
6	6,78	8,70	6,30	7,20	6,30	8,10	18	30	30	60	60	120	48	72	12	18
8	9,04	11,60	8,40	9,60	8,40	10,80	-	-	40	80	80	160	64	96	16	24
10	11,3	14,5	10,5	12,0	10,5	13,5	30	50	50	100	100	200	80	120	20	30
13	14,7	18,9	13,7	15,6	13,7	17,6	39	65	65	130	130	260	104	156	26	39
16	18,1	23,2	16,8	19,2	16,8	21,6	48	80	80	160	160	320	128	192	32	48
20	22,6	29,0	21,0	24,0	21,0	27,0	60	100	100	200	200	400	160	240	40	60
25	28,3	36,3	26,3	30,0	26,3	33,8	75	125	125	250	250	500	200	300	50	75
32	36,2	46,4	33,6	38,4	33,6	43,2	96	160	160	320	320	640	256	384	64	96
40	45,2	58,0	42,0	48,0	-	-	120	200	200	400	400	800	320	480	-	-
50	56,5	72,5	52,5	60,0	-	-	150	250	250	500	500	1000	400	600	-	-
63	71,2	91,4	66,2	75,6	-	-	189	315	315	630	630	1260	504	756	-	-

MINIATURE CIRCUIT BREAKERS S, SL AND T PRODUCT RANGES

Short circuit selectivity

6 kA miniature circuit breakers, S and SL product ranges												
Short circuit selectivity to fuses in kA												
Rated current I _n (A)												
Characteristic	B	6	10	13	16	20	25	32	40	50	63	
	C	6	10	13	16	20	25	32	40	50	63	
LV HRC fuse Characteristic gL/gG according to DIN VDE 0636	I _n (A)	25	0,85 0,7	0,8 0,7	0,8 0,7	0,75 0,65	0,7 0,6	0,6 0,55				
		35	1,6 1,3	1,6 1,3	1,5 1,25	1,5 1,2	1,4 1,2	1,2 1,1	1,1 1,0	0,8 0,7		
		50	2,4 2,1	2,35 2,1	2,3 2,0	2,3 2,0	2,2 1,9	1,6 1,5	1,5 1,4	1,3 1,2	1,2 1,1	
		63	3,5 2,9	3,3 2,8	3,2 2,7	3,2 2,7	3,0 2,6	2,5 2,1	2,4 2,0	1,8 1,6	1,7 1,5	1,6 1,4
		80	5,0 4,1	4,8 4,0	4,7 3,9	4,6 3,9	4,3 3,6	3,4 2,8	3,3 2,8	2,5 2,1	2,4 2,0	2,3 1,9
		100	6,0 6,0	6,0 6,0	6,0 5,9	6,0 5,7	6,0 5,0	5,1 4,0	5,0 3,9	3,5 2,9	3,3 2,8	3,1 2,6
		125	6,0 6,0	6,0 6,0	6,0 6,0	6,0 6,0	6,0 6,0	6,0 6,0	6,0 6,0	5,4 4,5	5,1 4,3	4,9 4,1

10 kA miniature circuit breakers, T product range												
Short circuit selectivity to fuses in kA												
Rated current I _n (A)												
Characteristic	B	6	10	13	16	20	25	32	40	50	63	
	C	6/8	10	13	16	20	25	32	40	50	63	
	D	6/8	10	13	16	20	25	32	40	50	63	
LV HRC fuse Characteristic gL/gG according to DIN VDE 0636	I _n (A)	25	0,85 0,7	0,8 0,7	0,8 0,7	0,75 0,65	0,7 0,6	0,6 0,55				1.)
		35	1,6 1,3	1,6 1,3	1,5 1,25	1,5 1,2	1,4 1,2	1,2 1,1	1,1 1,0	0,8 0,7		
		50	2,4 2,1	2,35 2,1	2,3 2,0	2,3 2,0	2,2 1,9	1,6 1,5	1,5 1,4	1,3 1,2	1,2 1,1	
		63	3,5 2,9	3,3 2,8	3,2 2,7	3,2 2,7	3,0 2,6	2,5 2,1	2,4 2,0	1,8 1,6	1,7 1,5	1,6 1,4
		80	5,0 4,1	4,8 4,0	4,7 3,9	4,6 3,9	4,3 3,6	3,4 2,8	3,3 2,8	2,5 2,1	2,4 2,0	2,3 1,9
		100	7,6 6,3	7,3 6,1	7,1 5,9	7,0 5,7	6,5 5,0	5,1 4,0	5,0 3,9	3,5 2,9	3,3 2,8	3,1 2,6
		125	10 10	10 10	10 10	10 10	10 10	8,8 8,7	8,5 8,5	5,4 4,5	5,1 4,3	4,9 4,1
			8,8	8,0	7,7	7,6	7,1	5,7	5,6	3,8	3,6	3,5

1.) There is no more overload selectivity above the step line.

MINIATURE CIRCUIT BREAKERS S AND T PRODUCT RANGES

Short circuit selectivity

10KA Miniature circuit breakers, T product range · Short circuit selectivity to Miniature Circuit breakers in A											
		Rated current I _n (A)									
Characteristic	B	6	10	13	16	20	25	32	40	50	63
	C	6	10	13	16	20	25	32	40	50	63
	D	6	10	13	16	20	25	32	40	50	63
Miniature circuit breakers B-characteristic (A)	20	80	80								
	25	100	100	100	100						
	32	125	125	125	125	125					
	40	160	160	160	160	160	160				
	50	200	200	200	200	200	200	200			
	63	250	250	250	250	250	250	250	250		
	80	350	350	350	350	350	350	350	350		
	100	450	450	450	450	450	450	450	450	450	450
	125	500	500	500	500	500	500	500	500	500	500

10KA Miniature circuit breakers, T product range · Short circuit selectivity to Miniature Circuit breakers in A											
		Rated current I _n (A)									
Characteristic	B	6	10	13	16	20	25	32	40	50	63
	C	6	10	13	16	20	25	32	40	50	63
	D	6	10	13	16	20	25	32	40	50	63
Miniature circuit breakers C-characteristic (A)	20	160	160								
	25	200	200	200	200						
	32	250	250	250	250	250					
	40	320	320	320	320	320	320				
	50	400	400	400	400	400	400	400			
	63	500	500	500	500	500	500	500	500		
	80	600	600	600	600	600	600	600	600	600	
	100	1500	700	700	700	700	700	700	700	700	700
	125	1500	800	800	800	800	800	800	800	800	800

MINIATURE CIRCUIT BREAKERS S AND T PRODUCT RANGES

Short circuit selectivity

10KA Miniature circuit breakers, T product range · Short circuit selectivity to Miniature Circuit breakers in A												
		Rated current I _n (A)										
Characteristic	B	6	10	13	16	20	25	32	40	50	63	
	C		6	10	13	16	20	25	32	40	50	63
	D		6	10	13	16	20	25	32	40	50	63
Miniature circuit breakers D-characteristic (A)	20	250	250	250								
		250	250	250								
		250	250	250								
	25	300	300	300	300							
		300	300	300	300							
		300	300	300	300							
	32	400	400	400	400	400						
		400	400	400	400	400						
		400	400	400	400	400						
40	500	500	500	500	500	500						
	500	500	500	500	500	500						
	500	500	500	500	500	500						
50	630	630	630	630	630	630	630					
	630	630	630	630	630	630	630					
	630	630	630	630	630	630	630					
63	800	800	800	800	800	800	800	800				
	800	800	800	800	800	800	800	800				
	800	800	800	800	800	800	800	800				
80	1250	1250	1250	1250	1250	1250	1250	1250	1250			
	1250	1250	1250	1250	1250	1250	1250	1250	1250			
	1250	1250	1250	1250	1250	1250	1250	1250	1250			
100	3000	1500	1500	1500	1500	1500	1500	1500	1500	1500		
	3000	1500	1500	1500	1500	1500	1500	1500	1500	1500		
	3000	1500	1500	1500	1500	1500	1500	1500	1500	1500		
125	6000	3000	3000	3000	3000	3000	1500	1500	1500	1500		
	6000	3000	3000	3000	3000	3000	1500	1500	1500	1500		
	6000	3000	3000	3000	3000	3000	1500	1500	1500	1500		

MINIATURE CIRCUIT BREAKERS DC PRODUCT RANGE

6 kA B and C characteristic acc. to IEC 60898-2



6000 T15 **twin** **fix**

RATED CURRENT I_n A	CHARACTERISTIC		WEIGHT g / EACH	PACKING UNIT
	B ARTICLE NO.	C ARTICLE NO.		

1-pole				
0.5		C0.5DC1	120	12
1	B1DC1	C1DC1	120	12
2	B2DC1	C2DC1	120	12
3	B3DC1	C3DC1	120	12
4	B4DC1	C4DC1	120	12
6	B6DC1	C6DC1	120	12
10	B10DC1	C10DC1	120	12
13	B13DC1	C13DC1	120	12
16	B16DC1	C16DC1	120	12
20	B20DC1	C20DC1	120	12
25	B25DC1	C25DC1	120	12
32	B32DC1	C32DC1	120	12
40	B40DC1	C40DC1	120	12
50	B50DC1	C50DC1	120	12
63	B63DC1	C63DC1	120	12



6000 T15 **twin** **fix**

2-pole				
0,5		C0.5DC2	240	6
1	B1DC2	C1DC2	240	6
2	B2DC2	C2DC2	240	6
3	B3DC2	C3DC2	240	6
4	B4DC2	C4DC2	240	6
6	B6DC2	C6DC2	240	6
10	B10DC2	C10DC2	240	6
13	B13DC2	C13DC2	240	6
16	B16DC2	C16DC2	240	6
20	B20DC2	C20DC2	240	6
25	B25DC2	C25DC2	240	6
32	B32DC2	C32DC2	240	6
40	B40DC2	C40DC2	240	6
50	B50DC2	C50DC2	240	6
63	B63DC2	C63DC2	240	6

MINIATURE CIRCUIT BREAKERS DC PRODUCT RANGE

Technical Data

Characteristic		B	C
Application		Wiring protection	Wiring protection Device protection
Number of poles		1 and 2	
Standards		IEC 60898-2, DIN EN 60898-2, VDE 0641-12	
Rated switching capacity: DC L/R = 4 ms		6 kA	6 kA
Max. back-up fuse		Fuse according to DIN VDE 0636 100 A operating class gL/gG	
Rated DC voltage L/R = 15 ms		1-pole 125 V, 2-pole 250 V in serial connection of both poles	
Rated current range I_n			
Product range „DC“		1 - 63 A	0.5 - 63 A
Test currents	Thermal not tripping I_1 (A) > 1 h	$1.13 \times I_n$	$1.13 \times I_n$
	Thermal tripping I_2 (A) < 1 h	$1.45 \times I_n$	$1.45 \times I_n$
	Electromagnetic not tripping I_4 (A) > 0.1 s	$4 \times I_n$	$7 \times I_n$
	Electromagnetic tripping I_5 (A) < 0.1 s	$7 \times I_n$	$15 \times I_n$
Reference calibration temperature of the thermal tripping		30 °C + 5 °C Influence of the ambient temperature on the thermal tripping: Decrease of the current values with higher ambient temperature and increase with lower temperatures of approximately 5% per 10 °C difference in temperature	
Ambient temperature		-25 °C to +55 °C	
Storage temperature		-40 °C to +70 °C	
Device depth acc. to DIN 43880		68 mm	
Mechanical endurance		20,000 switching cycles (20,000 ON/20,000 OFF)	
Protection cover		Finger safe and safe to back of hand according to DIN EN 50274/VDE0660-514, BGV A3	
Degree of protection acc. to EN 60529 / IEC 60529		IP20	
Installation position		any	
Mounting		DIN-rail according to DIN EN 60715, 35 mm	
Lockability		The handle can be secured against manual switching in the on and off position by a lead seal	
Climatic resistance		Humid heat constant according to DIN IEC 60068-2-78 Humid heat cycle according to DIN EN 60068-2-30	
Vibration resistance		> 15 g according to DIN EN 60068-2-59 during a load with I_1	
Resistance to mechanical shocks		25g 11ms	

Conductor cross sections				
Type of conductor *)	Box terminal bottom		Box terminal top	
	max.	min.	max.	min.
Single wire	35 mm ²	0,5 mm ²	25 mm ²	0,5 mm ²
Multiple wire	35 mm ²	1,5 mm ²	25 mm ²	1,5 mm ²
Stranded wire	25 mm ²	1 mm ²	16 mm ²	1 mm ²
Stranded wire with ferrule	16 mm ²	0,5 mm ²	16 mm ²	0,5 mm ²
Busbar cable lug	Up to 3 mm thickness		Up to 3 mm thickness	
Combined, conductor and busbar or cable lug	Up to 35 mm ² and up to 2 mm thickness		Up to 25 mm ² and up to 2 mm thickness	
Torque	max. 2,5 Nm			

*) Stripped length 12–14 mm

MINIATURE CIRCUIT BREAKERS DC PRODUCT RANGE

Characteristic

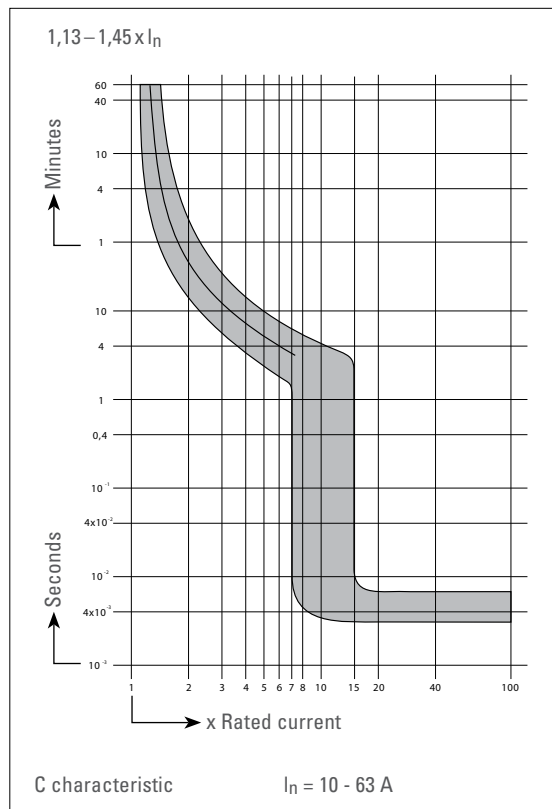
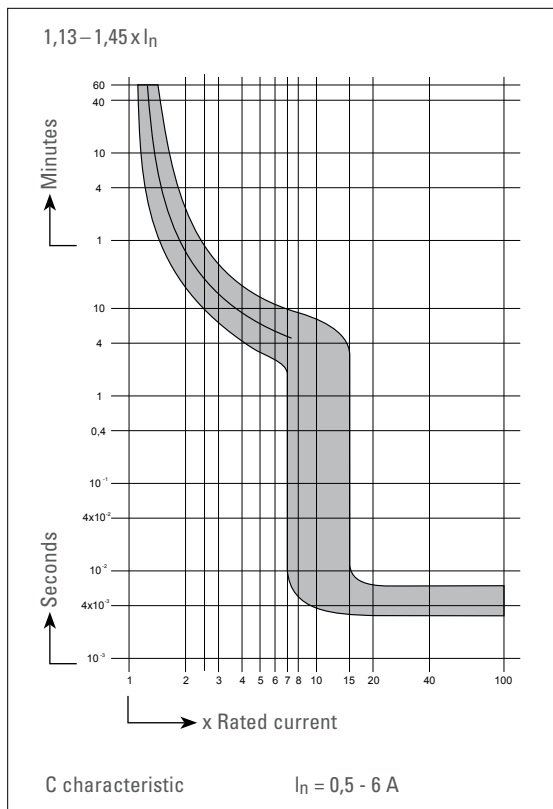
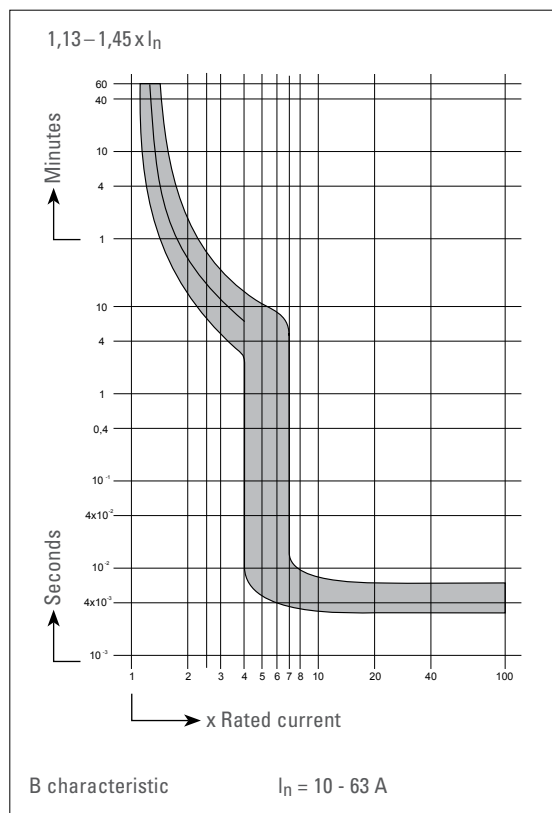
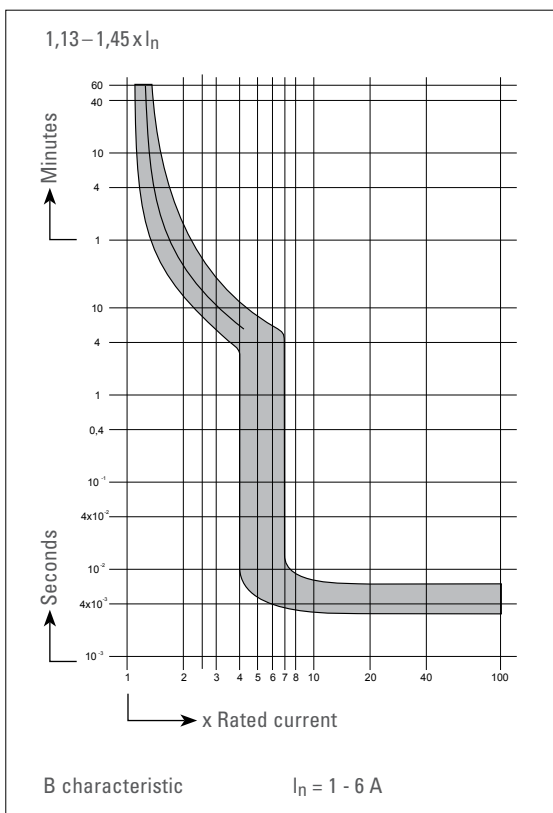

ACCESSORIES MINIATURE CIRCUIT BREAKERS

S, SL, T and DC product ranges



Shunt trip

MODULE	RATED OPERATING VOLTAGE	MAX. OPERATING CURRENT AT U_n (T < 10 ms)	ARTICLE NO.	WEIGHT g/EACH	PACKING UNIT
1	12 V UC	1,3 A	FL12	105	5
1	24 V UC	0,6 A	FL24	105	5
1	48 - 72 V UC	0,2 A	FL48	105	5
1	110-230 V UC, 400 V AC	0,25 A bei 110 V	FL110	105	5
		0,5 A bei 230 V			
		0,8 A bei 400 V			

Pull-in voltage $0.7 \times U_e$ Switch in duration at U_e 100%



Undervoltage trip (50/60 Hz)

MODULE	RATED VOLTAGE	ARTICLE NO.	WEIGHT g/EACH	PACKING UNIT
1	220-230 V 50 Hz, 240 V 60 Hz	UL230	150	5
	other types on request			

Pull-in voltage $0.85 \times U_e$ Drop-out voltage $0.35 - 0.7 \times U_e$ Switch in duration at U_e 100%



Single Pole Miniature Circuit Breaker, 10 A, B Characteristic for the special designation of circuits e.g. fire warning and telephone systems etc.

RATED CURRENT I_n [A]	ARTICLE NO.	WEIGHT g/EACH	PACKING UNIT
10	B10T1R	150	12



Distance device 9 mm

MODULE	ARTICLE NO.	WEIGHT g/EACH	PACKING UNIT
1/2	ISD	13	10



Lock-off/Lock-on device

ARTICLE NO.	WEIGHT g/EACH	PACKING UNIT
EASS	2	10

ACCESSORIES MINIATURE CIRCUIT BREAKERS

S, SL, T and DC product ranges



Auxiliary contact

MODULE	TYPE OF CONTACT	CONTACTS	ARTICLE NO.	WEIGHT g / EACH	PACKING UNIT
1/2	1 auxiliary contact	1NO	HL10	35	20
1/2	2 auxiliary contacts	1NO + 1NC	HL11	40	20
1/2	2 auxiliary contacts	1NO + 1NC	HL11L*	40	20
1/2	3 auxiliary contacts	1NO + 2NC	HL12	45	20
1/2	3 auxiliary contacts	2NO + 1NC	HL21	45	20

* Mounting on the left

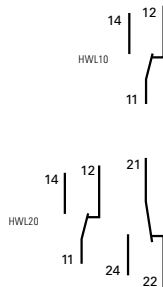

Auxiliary contact

MODULE	TYPE OF CONTACT	CONTACTS	ARTICLE NO.	WEIGHT g / EACH	PACKING UNIT
1/2	1 auxiliary contact	1 CO contact	HWL10	40	20
1/2	2 auxiliary contacts	2 CO contact	HWL20	50	20

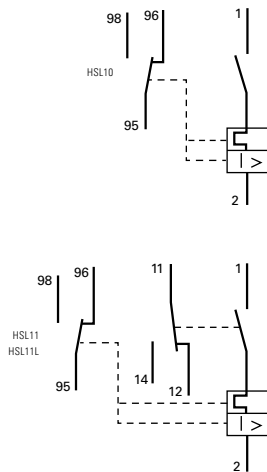

Auxiliary contact with signal contact

MODULE	TYPE OF CONTACT	CONTACTS	ARTICLE NO.	WEIGHT g / EACH	PACKING UNIT
1/2	1 signal contact / 1 auxiliary contact	2 CO contact	HSL11	50	20
1/2	1 signal contact / 1 auxiliary contact	2 CO contact	HSL11L*	50	20
1/2	1 signal contact	1 CO contact	HSL10	40	20

* Mounting on the left

The signal contact and the auxiliary contact are each fitted with a floating CO contact. Both contacts have trip-free mechanisms, i.e. manipulating the contact positions from outside is not possible. The signal contact indicates overload or short circuit of the main device while the auxiliary contact shows the switch condition (on/off).

Technical Data		HL10, HL11/L, HL12, HL21	HWL10, HWL20, HSL10, HSL11/L
Standards		IEC 60947-5-1, DIN EN 60947-5-1, VDE 0660-200	
Rated voltage		230 V~	
Conventional thermal current in enclosure		I _{the} 16 A	
Rated operating currents I _e	Usage category AC-15 Usage category AC-15 Usage category DC-13 Usage category DC-13	10 A / 230 V 16 A / 110 V 1 A / 250 V 3 A / 125 V	4.8 A / 230 V 9.6 A / 120 V 1.8 A / 250 V 3.5 A / 125 V
Minimum switching capacity		0.05 VA at 6 V UC	

Conductor cross sections for all auxiliary contacts		
Type of conductor *)	max.	min.
Single wire	0,5 mm ²	2,5 mm ²
Stranded wire	0,5 mm ²	1,5 mm ²
Stranded wire with ferrule	0,5 mm ²	1,5 mm ²

*) Stripped length 8–9 mm

BUSBARS

for S, SL, T and DC miniature circuit breakers

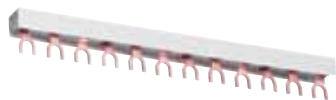

Busbars fork type

CROSS SECTION (mm ²)	BUSBAR CURRENT START OF BUSBAR/ MIDDLE INFEEED	MODULES/ PHASES	ARTICLE NO.	WEIGHT g/ EACH	PACKING UNIT	SUITABLE END CAP ARTICLE NO.
----------------------------------	--	-----------------	-------------	----------------	--------------	------------------------------

1-phase						
12	65/110	56	SB16010	250	50	

1-phase 1-pole circuit breaker + auxiliary contact						
24	90/150	37/1	SDO.124	200	50	

2-phase and 1-phase + N						
10	63/100	28/2	SB26010	390	20	SB.A5

3-phase + N, L1/N, L2/N, L3/N, for MCB 1+N, 2 modules						
16	80/130	27/2 3+N	SB41627	725	15	SB.A3

2-phase 2-pole circuit breaker + auxiliary contact						
16	80/130	22/2	SB26216	310	20	SB.A2

3-phase						
10	63/100	4/3	SB31210	84	25	SB.A1
10	63/100	19/3	SB36010	420	20	SB.A1
16	80/130	19/3	SB36016	675	20	SB.A2

3-phase 3-pole circuit breaker + auxiliary contact						
16	80/130	16/3	SB36316	630	20	SB.A2

3-phase 1-pole circuit breaker + auxiliary contact						
16	80/130	36/1	SDO.316	500	20	SB.A2

4-phase and 3-phase + N						
16	80/130	14/4	SB46016	835	15	SB.A3



End caps for busbars

FOR BUSBARS ARTICLE NO.	ARTICLE NO.	WEIGHT g/ EACH	PACKING UNIT
-------------------------	-------------	----------------	--------------

SB31210, SB36010	SB.A1	0,8	10
SB36016, SB36316, SDO.316, SB41627, SB26216	SB.A2	1	10
SB46016	SB.A3	1,1	10
SB26010	SB.A5	0,8	10

BUSBARS

for S, SL, and T miniature circuit breakers

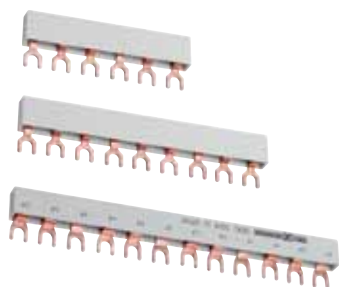

Busbars fork type

CROSS SECTION (mm ²)	BUSBAR CURRENT START OF BUSBAR/ MIDDLE INFEED	NUMBER OF POLES	ARTICLE NO.	WEIGHT g / EACH	PACKING UNIT
----------------------------------	---	-----------------	-------------	-----------------	--------------

3-phase

10	63	6	G31006	37	25
10	63/100	9	G31009	60	25
10	63/100	12	G31012	84	25

16	80	6	G31606	52	20
16	80/130	9	G31609	87	20
16	80/130	12	G31612	119	20



Busbars cannot be cut to length!



Busbars fork type

3-phase for left-hand RCCB installation in the distribution board (N omitted)

10	63	11	G31011S	82	25
16	80	11	G31611S	117	20

3-phase for right-hand RCCB installation in the distribution unit

16	80	11	G31611	108	20
----	----	----	---------------	-----	----



Busbars cannot be cut to length!

MINIATURE CIRCUIT BREAKERS T 80/100/125 A

B, C and D characteristic 10 kA acc. to IEC 60898-1, DIN EN 60898-1, VDE 0641-11



10000

RATED CURRENT I_n A	CHARACTERISTIC			WEIGHT g/EACH	PACKING UNIT
	B ARTICLE NO.	C ARTICLE NO.	D ARTICLE NO.		

1-pole					
80	B80T1	C80T1	D80T1	222	6
100	B100T1	C100T1	D100T1	222	6
125	B125T1	C125T1	D125T1	222	6



10000

2-pole					
80	B80T2	C80T2	D80T2	448	3
100	B100T2	C100T2	D100T2	448	3
125	B125T2	C125T2	D125T2	448	3



10000

3-pole					
80	B80T3	C80T3	D80T3	674	2
100	B100T3	C100T3	D100T3	674	2
125	B125T3	C125T3	D125T3	674	2



10000

4-pole					
80	B80T4	C80T4	D80T4	900	1
100	B100T4	C100T4	D100T4	900	1
125	B125T4	C125T4	D125T4	900	1

MINIATURE CIRCUIT BREAKERS T 80/100/125 A

Technical Data

Technical data	
Standards	EN 60898-1, GOST-R
Number of poles	1, 2, 3, 4
Tripping characteristics	B, C, D according to EN 60898-1
Rated voltage U_n [V]	230/400
Rated current I_n [A]	80, 100, 125
Breaking capacity [kA]	10
Rated frequency [Hz]	50 - 60
Electrical endurance	4,000 switching cycles
Cross-section of conductors [mm ²]	2.5 - 50
Mounting	on DIN rail 35 x 7.5 mm according EN 60715
Protection degree	IP 20
Ambient temperature	-5°C till +40°C
Operating position	optional
Rated DC voltage U_n [V]	max. 110 DC (for one pole, $t=4$ ms)
Sealable	in the ON or OFF position

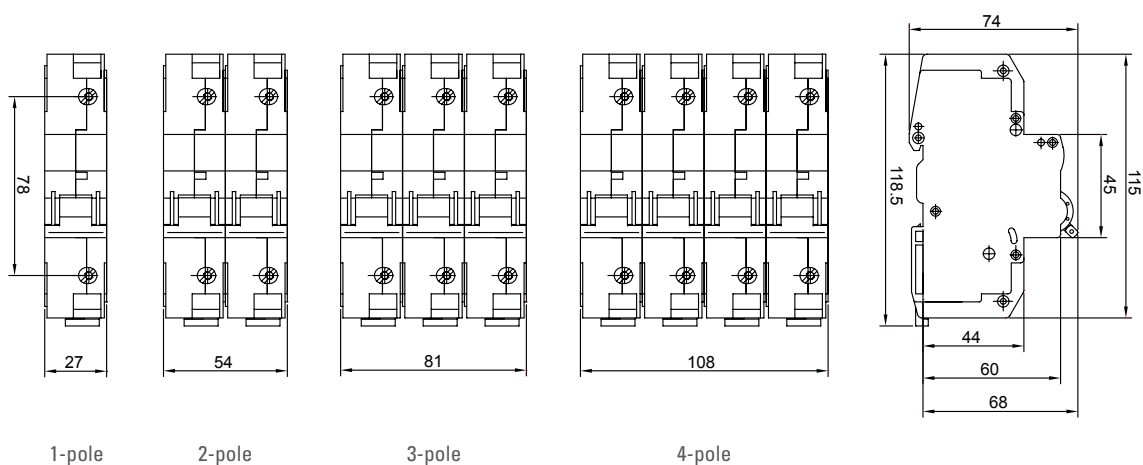

1-pole

2-pole

3-pole

4-pole

MINIATURE CIRCUIT BREAKERS 80/100/125 A

Technical Data

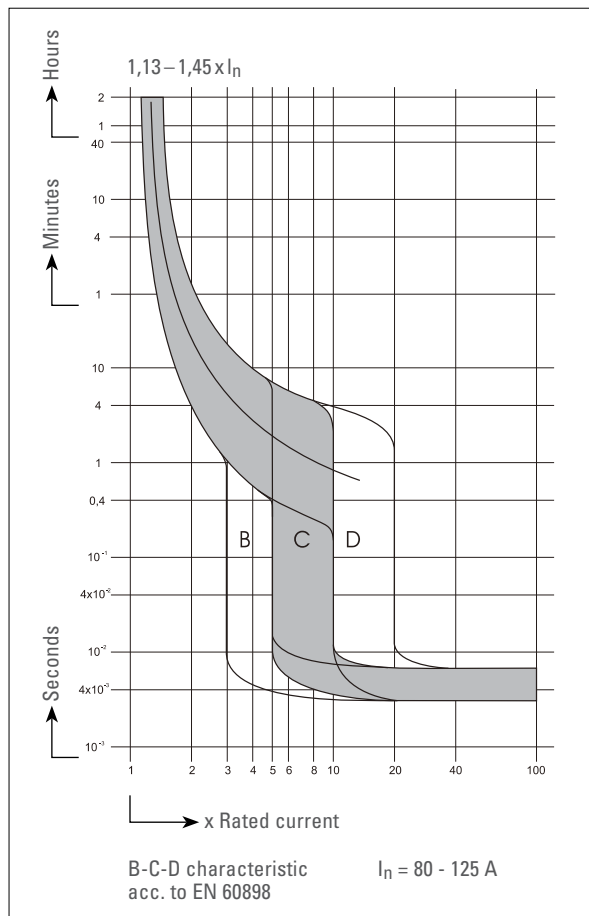

ACCESSORIES FOR MINIATURE CIRCUIT BREAKERS T 80/100/125 A

1-/2-/3-/4-pole

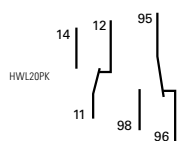
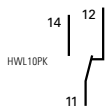

Auxiliary contact

MODULE	TYPE OF CONTACT	CONTACTS	ARTICLE NO.	WEIGHT g / EACH	PACKING UNIT
1/2	1 Auxiliary contact	1 CO	HWL10PK	43	10
1/2	2 Auxiliary contacts	2 CO	HWL20PK	48	10

Technical Data		HWL10PK	HWL20PK
Standards		IEC 60947-5-1, DIN EN 60947-5-1, VDE 0660-200	
Rated Voltage		230 V	
Rated isolation current		400 V	
Conventional thermal current in enclosure		I_{the} 16 A	
Rated operating currents I_e	Usage category AC-15 Usage category AC-14 Usage category DC-13 Usage category DC-13	4 A / 230 V 3,5 A / 400 V; 6,5 A / 230 V 0,25 A / 220 V; 0,5 A / 110 V 16 A / 24 V	

Conductor cross sections

Type of conductor *)	max.	min.
single wire	0,5 mm ²	2,5 mm ²
stranded wire	0,5 mm ²	1,5 mm ²
stranded wire with ferrule	0,5 mm ²	1,5 mm ²

*) Stripped length 8 - 9 mm

MINIATURE CIRCUIT BREAKERS 1+N PRODUCT RANGE

6 kA B and C characteristic acc. to IEC 60898-1



RATED CURRENT I_n A	CHARACTERISTIC		WEIGHT g / EACH	PACKING UNIT
	B ARTICLE NO.	C ARTICLE NO.		

1-pole with switched neutral, 1 module				
10	B10N8R	C10N8R	101	12
13	B13N8R	C13N8R	101	12
16	B16N8R	C16N8R	101	12
20	B20N8R	C20N8R	101	12
25	B25N8R	C25N8R	101	12
32	B32N8R	C32N8R	101	12



- ① Operating status display
- ② Miniature circuit breakers with switched neutral – in 1 module.

Technical Data

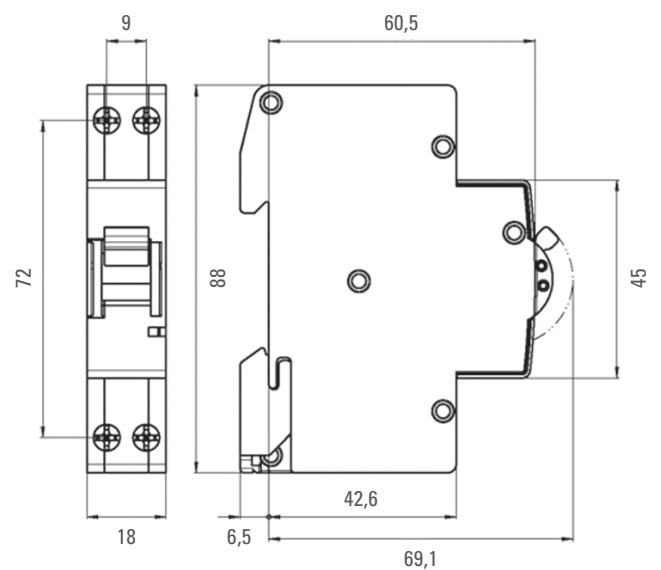
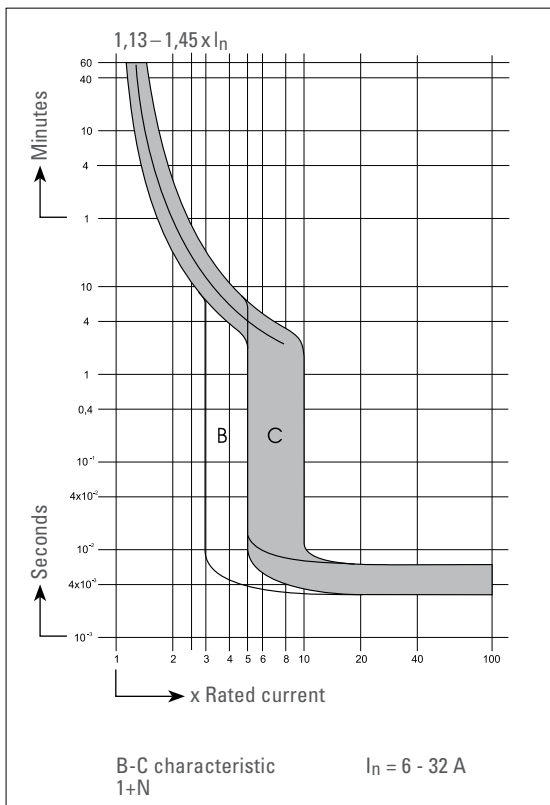

BUSBARS FOR MINIATURE CIRCUIT BREAKERS

1+N Product Range



Pin-type busbars for 1 + N miniature circuit breakers in 1M

CROSS SECTION (mm ²)	BUSBAR CURRENT	MODULES	PHASES	ARTICLE NO.	WEIGHT g/EACH	PACKING UNIT	SUITABLE END CAP ARTICLE NO.
----------------------------------	----------------	---------	--------	-------------	---------------	--------------	------------------------------

1-phase + N

10	63	12/2	1+N	SN11012	75	25	SB.A2
10	63	54/2	1+N	SN11054	350	20	SB.A2

3-phase + N, L1/N, L2/N, L3/N

16	80	12/2	3+N	SN31612	160	25	SB.A3
16	80	54/2	3+N	SN31654	720	15	SB.A3



Power feed terminals L grey

16	80			SBL1N	14	1	
----	----	--	--	-------	----	---	--

Power feed terminals N blue

16	80			SBN1N	14	1	
----	----	--	--	-------	----	---	--



SWITCHING DEVICES

RCCB AND RCBOS

RCCB

RW product range	42
Sensitive to alternating currents, Type AC	42
Undelayed tripping	42
Short-time delayed tripping	45
Selective tripping	45

RP product range

Sensitive to pulsating currents, Type A	46
Undelayed tripping	46
Short-time delayed tripping	48
Selective tripping	48

RA product range

Sensitive to universal current, Type B	49
Short-time delayed tripping	49
Selective tripping	51
Auxiliary contact	53
Technical data RP und RW	54
General explanations	57
Technical features and application notes	59

RCBO

RC and RB product range	65
Auxiliary contact	66
Busbars	66
Technical Data	67

RCCB – SENSITIVE TO ALTERNATING CURRENT TYPE AC

RW product range, undelayed tripping acc. to IEC 61008

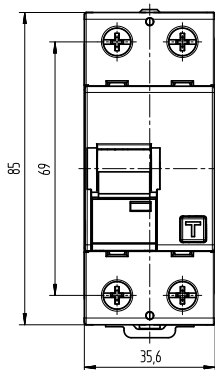

RW product range, 2-pole

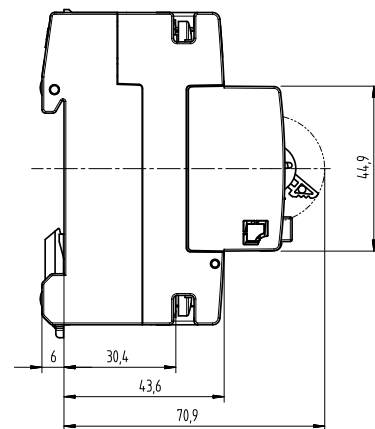
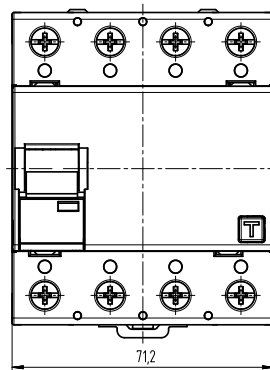

RW product range, 4-pole

Function

RCCB independent of the mains voltage for realising the protective measure "protection through automatic power supply cut-off", in compliance with the requirements of international construction regulations.

Characteristics

- 2-pole or 4-pole
 - Large range of products with
 - Rated currents from 16 A to 125 A
 - Rated residual currents 0.03 A to 0.5 A
 - Tripping independent of supply and auxiliary voltage
 - Sensitive to AC residual currents (type AC)
 - High short-circuit strength
 - Double-sided two-tier terminals for large conductor cross-section and busbar
 - Switch-position display
 - Window for labels
 - Multi-functional switching knob with three functions:
 - **On** (top position)
 - **Off** (bottom position)
 - Display **"tripped"** (centre position)
- If the RCCB trips due to a fault, the switching knob stays in the centre position

Type of mounting

- Quick mounting on DIN-rail in accordance with EN 60715 in any standard distribution
- Any mounting position

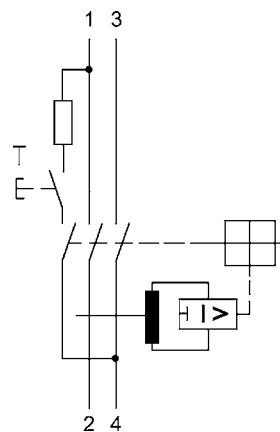

RW product range, 2-pole

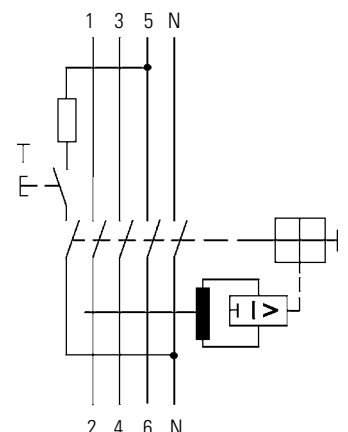

RW product range, 4-pole 25-80 A

Areas of application

Power supplies of residential and single-purpose buildings as well as industrial facilities with TN-S and TN-C-S networks. In IT networks, RCCBs of the RW series for switch-off in case of a second failure can be provided for. Excluded is the use in TN-C networks and for protecting systems in which electronic equipment might cause DC residual currents or residual currents with frequencies of $\neq 50$ Hz.

RCCB – SENSITIVE TO ALTERNATING CURRENT TYPE AC

Undelayed tripping acc. to IEC 61008

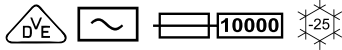

This product range differentiates between:

- Standard products (**shown in the table in bold**)
- Special products (shown in the table in normal print – longer delivery time)

RATED RESID. CURRENT $I_{\Delta n}$ mA	RATED CURRENT I_n A	SURGE CURRENT STRENGTH > A	MAX. BACK-UP FUSE A	MODULES	ARTICLE NO.	WEIGHT g/EACH	PACKING UNIT
--	-----------------------	----------------------------	---------------------	---------	-------------	---------------	--------------

2-pole, undelayed tripping							
30	16	250	63	2	RW2103	250	1
100	16	250	63	2	RW2110	250	1
300	16	250	63	2	RW2130	250	1
30	25	250	63	2	RW2203	250	1
100	25	250	63	2	RW2210	250	1
300	25	250	63	2	RW2230	250	1
30	40	250	63	2	RW2303	260	1
100	40	250	63	2	RW2310	260	1
300	40	250	63	2	RW2330	260	1
30	63	250	100	2	RW2403	270	1
100	63	250	100	2	RW2410	270	1
300	63	250	100	2	RW2430	270	1

RCCB – SENSITIVE TO ALTERNATING CURRENT TYPE AC

Undelayed tripping acc. to IEC 61008

This product range differentiates between:

- Standard products (**shown in the table in bold**)
- Special products (shown in the table in normal print – longer delivery time)

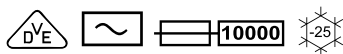

RATED RESID. CURRENT $I_{\Delta n}$ mA	RATED CURRENT I_n A	SURGE CURRENT STRENGTH > A	MAX. BACK-UP FUSE A	MODULES	ARTICLE NO.	WEIGHT g/EACH	PACKING UNIT
---	--------------------------	-------------------------------	------------------------	---------	-------------	------------------	-----------------

4-pole, undelayed tripping							
30	16	250	63	4	RW4103	450	1
100	16	250	63	4	RW4110	450	1
300	16	250	63	4	RW4130	450	1
30	25	250	63	4	RW4203	450	1
100	25	250	63	4	RW4210	450	1
300	25	250	63	4	RW4230	450	1
30	40	250	63	4	RW4303	450	1
100	40	250	63	4	RW4310	450	1
300	40	250	63	4	RW4330	450	1
30	63	250	100	4	RW4403	450	1
100	63	250	100	4	RW4410	450	1
300	63	250	100	4	RW4430	450	1
30	80	250	125	4	RW4503	470	1
300	80	250	125	4	RW4530	470	1
500	80	250	125	4	RW4550	470	1
30	100	250	125	4	RW4603	470	1
100	100	250	125	4	RW4610	470	1
300	100	250	125	4	RW4630	470	1
30	125	250	125	4	RW4703	470	1
100	125	250	125	4	RW4710	470	1
300	125	250	125	4	RW4730	470	1
500	125	250	125	4	RW4750	470	1

RCCB – SENSITIVE TO ALTERNATING CURRENT TYPE AC

Short-time delayed tripping acc. to IEC 61008



RATED RESID. CURRENT $I_{\Delta n}$ mA	RATED CURRENT I_n A	SURGE CURRENT STRENGTH > A	MAX. BACK- UP FUSE A	MODULES	ARTICLE NO.	WEIGHT g / EACH	PACKING UNIT
--	-----------------------------	----------------------------------	----------------------------	---------	-------------	--------------------	-----------------

4-pole, short-time delayed tripping							
30	40	3,000	63	4	RW4303K	450	1
30	63	3,000	100	4	RW4403K	450	1

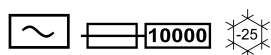

RCCB – SENSITIVE TO ALTERNATING CURRENT TYPE AC

Selective tripping acc. to IEC 61008



RATED RESID. CURRENT $I_{\Delta n}$ mA	RATED CURRENT I_n A	SURGE CURRENT STRENGTH > A	MAX. BACK- UP FUSE A	MODULES	ARTICLE NO.	WEIGHT g / EACH	PACKING UNIT
--	-----------------------------	----------------------------------	----------------------------	---------	-------------	--------------------	-----------------

4-pole, short-time delayed tripping							
300	40	5,000	63	4	RW4330S	450	1
300	63	5,000	100	4	RW4430S	450	1
300	100	5,000	125	4	RW4630S	450	1
300	125	5,000	125	4	RW4730S	450	1

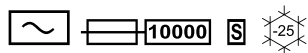

RCCB – SENSITIVE TO PULSATING CURRENTS, TYPE A

RP product range, undelayed tripping acc. to IEC 61008

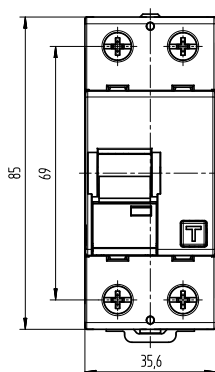

RP product range, 2-pole

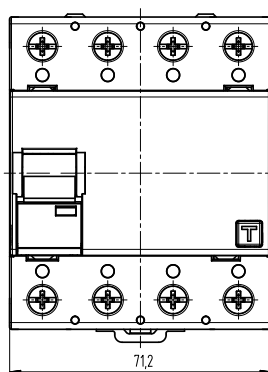

RP product range 4-pole

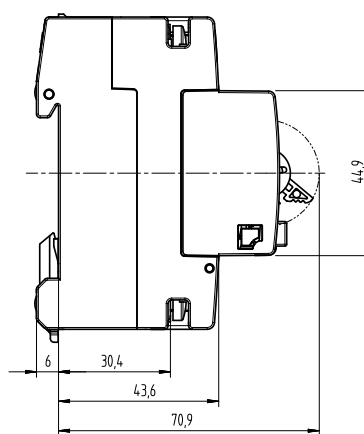

Function

RCCB independent of the mains voltage for realising the protective measure "protection through automatic power supply cut-off", in compliance with the requirements of VDE 0100 part 410 and corresponding international construction regulations.

Characteristics

- 2-pole or 4-pole
- Large range of products with
 - Rated currents from 16 A to 125 A
 - Rated residual currents 0.03 A to 0.5 A
- Tripping independent of supply and auxiliary voltage
- Sensitive to AC and pulsating DC residual currents (type A)
- High short-circuit strength
- Double-sided two-tier terminals for large conductor cross-section and busbar
- Switch-position display
- Window for labels
- Multi-functional switching knob with three functions:
 - **On** (top position)
 - **Off** (bottom position)
 - Display "**tripped**" (centre position)

If the RCCB trips due to a fault, the switching knob stays in the centre position.

Type of mounting

- Quick mounting on DIN-rail according to EN 60715 in any standard distribution
- Any mounting position

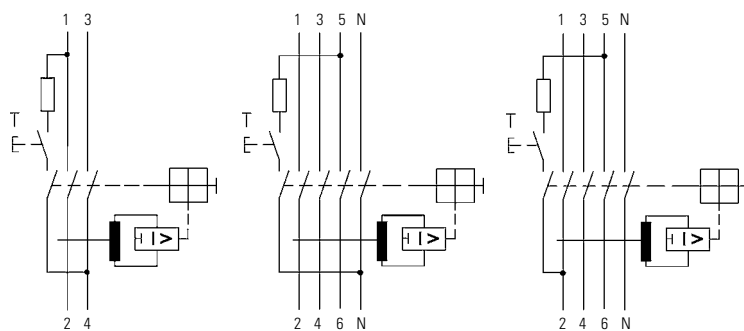

RP product range, 2-pole

RP product range, 4-pole
25-80 A

Areas of application

Power supplies of residential and single-purpose buildings as well as industrial facilities with TN-S and TN-C-S networks. In IT networks, RCCBs of the RP range for switch-off in case of a second fault can be provided for.

The use in TN-C networks and for protecting systems in which electronic equipment might cause DC residual currents or residual currents with frequencies of $\neq 50$ Hz is excluded.

RCCB – SENSITIVE TO PULSATING CURRENTS, TYPE A

Undelayed tripping acc. to IEC 61008

This product range differentiates between:

- Standard products (**shown in the table in bold**)
- Special products (shown in the table in normal print – longer delivery time)

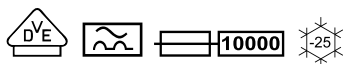

RATED RESID. CURRENT $I_{\Delta n}$ mA	RATED CURRENT I_n A	SURGE CURRENT STRENGTH > A	MAX. BACK-UP FUSE A	MODULES	ARTICLE NO. N-POL RIGHT	ARTICLE NO. N-POL LEFT	WEIGHT g / EACH	PACKING UNIT
--	-----------------------------	-------------------------------	------------------------	---------	-------------------------------	------------------------------	--------------------	-----------------

2-pole, undelayed tripping								
10	16	250	50	2	RP2101		270	1
30	25	250	100	2	RP2203		270	1
300	25	250	100	2	RP2230		270	1
30	40	250	100	2	RP2303		270	1
300	40	250	100	2	RP2330		270	1
30	63	250	100	2	RP2403		270	1
300	63	250	100	2	RP2430		270	1
500	63	250	100	2	RP2450		270	1

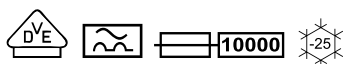

4-pole, undelayed tripping								
30	25	250	100	4	RP4203	RP4203L	450	1
300	25	250	100	4	RP4230	RP4230L	420	1
500	25	250	100	4	RP4250	RP4250L	420	1
30	40	250	100	4	RP4303	RP4303L	450	1
300	40	250	100	4	RP4330	RP4330L	420	1
500	40	250	100	4	RP4350	RP4350L	420	1
30	63	250	100	4	RP4403	RP4403L	450	1
300	63	250	100	4	RP4430	RP4430L	420	1
500	63	250	100	4	RP4450	RP4450L	420	1
30	80	250	125	4	RP4503		460	1
300	80	250	125	4	RP4530		430	1
500	80	250	125	4	RP4550		430	1
30	100	250	125	4	RP4603		460	1
300	100	250	125	4	RP4630		430	1
500	100	250	125	4	RP4650		430	1
30	125	250	125	4	RP4703		460	1
300	125	250	125	4	RP4730		430	1
500	125	250	125	4	RP4750		430	1

RCCB – SENSITIVE TO PULSATING CURRENTS, TYPE A

Short-time delayed tripping acc. to IEC 61008

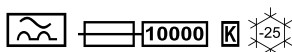

RATED RESID. CURRENT $I_{\Delta n}$ mA	RATED CURRENT I_n A	SURGE CURRENT STRENGTH > A	MAX. BACK-UP FUSE A	MODULES	ARTICLE NO.	WEIGHT g / EACH	PACKING. UNIT
--	-----------------------------	-------------------------------	------------------------	---------	-------------	--------------------	------------------

4-pole, short-time delayed tripping							
30	40	3.000	100	4	RP4303K	430	1
30	63	3.000	100	4	RP4403K	430	1

Areas of application

- Power supplies of residential and single-purpose buildings as well as industrial facilities with TN-S and TN-C-S networks, where normal RCCBs unwantedly trip as a result of transient drainage currents, such as
- Systems with long cable lengths behind the RCCB
- Lighting systems with many fluorescent lamps (> 20 pieces)
- Computer systems
- Solaria
- X-ray systems
- The use in TN-C networks and in systems in which electronic equipment might cause smooth DC residual currents or residual currents with frequencies of $\neq 50$ Hz is excluded.

RCCB – SENSITIVE TO PULSATING CURRENTS, TYPE A

Selective tripping acc. to IEC 61008

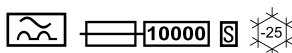

RATED RESID. CURRENT $I_{\Delta n}$ mA	RATED CURRENT I_n A	SURGE CURRENT STRENGTH > A	MAX. BACK-UP FUSE A	MODULES	ARTICLE NO.	WEIGHT g / EACH	PACKING. UNIT
--	-----------------------------	-------------------------------	------------------------	---------	-------------	--------------------	------------------

4-pole, selective tripping							
300	40	5.000	100	4	RP4330S	430	1
300	63	5.000	100	4	RP4430S	450	1
300	100	5.000	125	4	RP4630S	460	1
300	125	5.000	125	4	RP4730S	460	1

Areas of application

Main distributors in extended electricity supply systems with TN-S and TN-C-S systems, e.g. for

- Camping sites
- Marinas
- Allotment colonies
- Fairgrounds
- etc.

Here, selective RCCBs mostly protect the cables from the main distribution to the sub-distributions. The use in TN-C networks and in systems in which electronic equipment might cause smooth DC residual currents or residual currents with frequencies of $\neq 50$ Hz is excluded.

Notes

To ensure the selectivity of the RCCB, the rated residual current of the RP4xxxS must be selected at least one level higher than that of the undelayed switch connected downstream.

RCCB – SENSITIVE TO UNIVERSAL CURRENT, TYPE B

RA product range – short-time delayed tripping acc. to IEC 61008

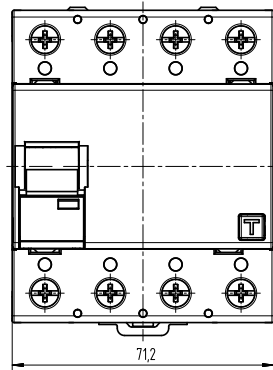

RAxxx product range, 4-pole
25 to 80 A

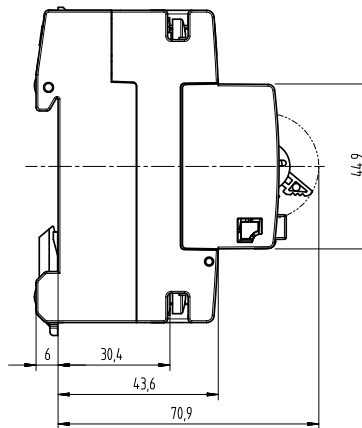

RAxxx product range, 4-pole
100 to 125 A

Function

RCCB sensitive to universal current for realising the protective measure “protection through automatic power-supply cut-off” in systems with electronic equipment, in compliance with the requirements of VDE 0100-410, VDE 0160, and corresponding international construction regulations. In addition to the mains-voltage-independent detection of AC and pulsating DC residual currents, all units of the RA4xxx product range are also able to detect smooth DC residual currents.

For this purpose, a voltage > 30 V between only two user-defined current paths is sufficient. The circuit breaker thus complies with type B according to IEC TR 60755.

Beyond this requirement, the RA4 consistently detects residual currents of all frequencies up to 1 MHz. With its low requirements concerning the auxiliary voltage and its large frequency range of residual current detection, this residual current circuit breaker clearly exceeds the requirements of the construction standard for B-type RCCBs, E DIN VDE 0664-100.

The frequency response of the RA4xxx tripping current (see figure on page 53) is designed such that residual currents with high frequencies, e.g. in the range of the pulse frequencies of frequency converters, are detected with clearly reduced sensitivity.

This largely prevents false tripping through drainage currents. However, even with residual currents of these frequencies, protection in case of indirect contact (fault protection) in compliance with VDE 0100-410 is realisable. The defined tripping threshold for all frequencies of up to 1 MHz always enables the definition of a maximum earth resistance, so that – in the event of fault – any inadmissibly high touch voltage will be switched off fast.

The devices of this range have different frequency responses for residual current tripping. In cases where capacitive drainage currents with the pulse frequencies of electronic equipment cause false tripping of the NK-type circuit breakers, an RA4xxx switch allows for mostly fault-free operation.

Even for rated residual currents ≤ 0.3 A, however, fire protection is only given for frequencies of up to approx. 1 kHz.

With this switch, protection in case of indirect contact, i.e. fault protection according to VDE 0100-410, can be realised at corresponding earth resistances throughout the entire frequency range of residual current tripping. The maximum permissible earth resistances result, as quotients, from the permissible touch voltage and the highest residual response current in the entire frequency range comprised.

RCCB – SENSITIVE TO UNIVERSAL CURRENT, TYPE B

RA product range – short-time delayed tripping acc. to IEC 61008

Characteristics

- 4-pole
- Sensitive to universal current for residual currents with frequencies and mixed frequencies from 0 to 1 MHz
- Large range of products with
 - Rated currents from 25 A to 125 A
 - Rated residual currents 0.03 A to 0.5 A
- Small size for all rated currents
- VDE test mark approved in compliance with
- DIN VDE 0664-10/E DIN VDE 0664-100
- Very unsusceptible to transient drainage and residual currents, due to delayed tripping response
- Electromagnetic compatibility in compliance with VDE 0664-30 and VDE 0839 6-2 (interference resistance for industrial use)
- High availability, also of the voltage-dependent detection of smooth DC and AC residual currents with frequencies \neq 50/60 Hz, due to full operability with mains voltages above 30 V, applied to any 2 current paths only
- Tripping at residual currents of type A, independent of mains voltage
- High short-circuit strength
- Double-sided two-tier terminals for large conductor cross-section and busbar connection
- Switch-position display
- Multi-functional switching knob with three functions:
 - **On** (top position)
 - **Off** (bottom position)
 - Display **"tripped"** (centre position)
- If the RCCB trips due to a fault, the switching knob stays in the centre position
- Window for labels

Type of mounting

- Quick mounting on DIN-rail in accordance with EN 60715 in any standard distribution
- Any mounting position
- Infeed direction from above (N, 1, 3, 5)

Areas of application

Commercial and industrial installations with TN-S and TN-C-S systems where power electronics equipment without galvanic mains separation is used, such as:

- Frequency converters
- UPS systems
- Switched-mode power supplies
- High-frequency converters
- On-site power supply distribution boards
- Photovoltaic systems

Note

Not intended for use in DC power supplies!

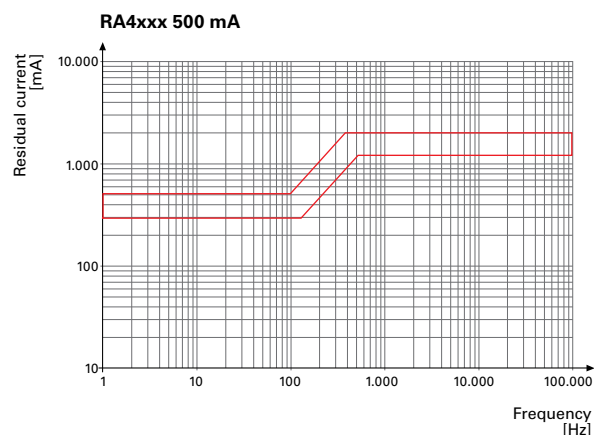
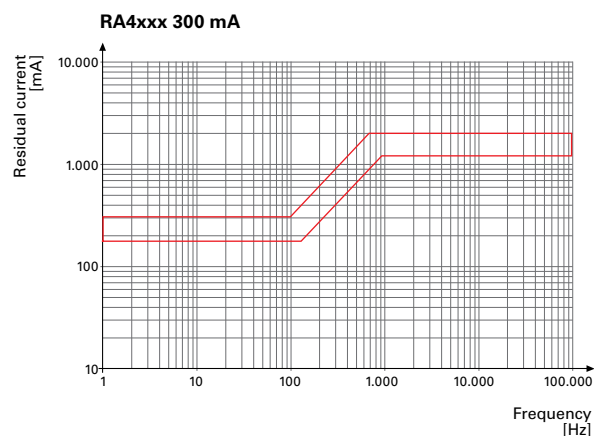
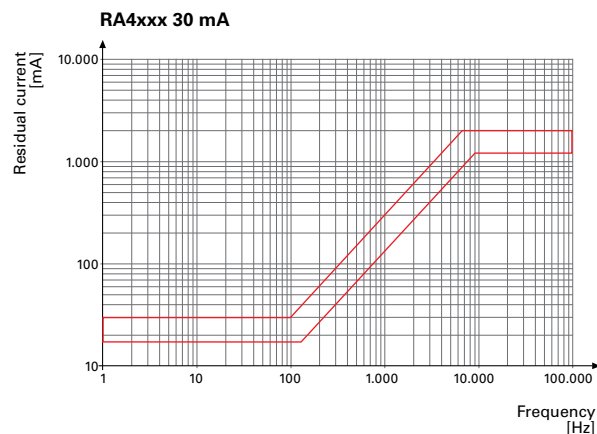

RCCB – SENSITIVE TO UNIVERSAL CURRENT, TYPE B

Short-time delayed tripping acc. to IEC 61008

This product range differentiates between:

- Standard products (**shown in the table in bold**)
- Special products (shown in the table in normal print – longer delivery time)

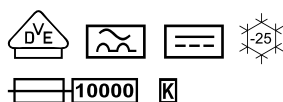

RATED RESID. CURRENT $I_{\Delta n}$ mA	RATED CURRENT I_n A	SURGE CURRENT STRENGTH > A	MAX. BACK-UP FUSE A	MODULES	ARTICLE NO.	WEIGHT g/EACH	PACKING UNIT
--	-----------------------------	-------------------------------	------------------------	---------	-------------	---------------	--------------

4-pole, short-time delayed tripping							
30	25	5.000	100	4	RA4203	450	1
300	25	5.000	100	4	RA4230	450	1
500	25	5.000	100	4	RA4250	450	1
30	40	5.000	100	4	RA4303	500	1
300	40	5.000	100	4	RA4330	500	1
500	40	5.000	100	4	RA4350	500	1
30	63	5.000	100	4	RA4403	500	1
300	63	5.000	100	4	RA4430	500	1
500	63	5.000	100	4	RA4450	500	1
30	80	5.000	125	4	RA4503	500	1
300	80	5.000	125	4	RA4530	500	1
500	80	5.000	125	4	RA4550	500	1
30	100	5.000	125	4	RA4603	500	1
300	100	5.000	125	4	RA4630	500	1
500	100	5.000	125	4	RA4650	500	1
30	125	5.000	125	4	RA4703	500	1
300	125	5.000	125	4	RA4730	500	1
500	125	5.000	125	4	RA4750	500	1

RCCB – SENSITIVE TO UNIVERSAL CURRENT, TYPE B

RA product range – selective tripping acc. to IEC 61008

Characteristics

- 4-pole
- Selectively to all undelayed RCCBs (type AC, A, or B) for residual currents of all frequencies in the detection range and for residual currents of type B
- Large range of products with
 - Rated currents from 40 A to 125 A
 - Rated residual currents 0.3 A
- Small size for all rated currents
- For systems with high drainage currents in the frequency range > 1 kHz
- Very unsusceptible to transient drainage and residual currents due to high surge current strength
- Electromagnetic compatibility in compliance with VDE 0664 part 30 and VDE 0839 part 6-2 (interference resistance for industrial use)
- High availability, also of the voltage-dependent detection of smooth DC and AC residual currents with frequencies \neq 50/60 Hz, due to full operability with mains voltages above 30 V, applied to any 2 current paths only
- Tripping at residual currents of type A, independent of mains voltage
- High short-circuit strength
- Double-sided two-tier terminals for large conductor cross-section and busbar connection
- Switch-position display
- Window for labels
- Multi-functional switching knob with three functions:
 - **On** (top position)
 - **Off** (bottom position)
 - Display **"tripped"** (centre position)
 If the RCCB trips due to a fault, the switching knob stays in the centre position

RCCB – SENSITIVE TO UNIVERSAL CURRENT, TYPE B

Selective tripping acc. to IEC 61008

This product range differentiates between:

- Standard products (**shown in the table in bold**)
- Special products (shown in the table in normal print – longer delivery time)

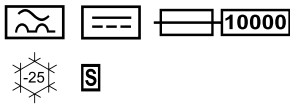

RATED RESID. CURRENT $I_{\Delta n}$ mA	RATED CURRENT I_n A	SURGE CURRENT STRENGTH > A	MAX. BACK-UP FUSE A	MODULES	ARTICLE NO.	WEIGHT g / EACH	PACKING. UNIT
--	-----------------------------	-------------------------------	------------------------	---------	-------------	--------------------	------------------

vierpolig, selektive Abschaltung							
300	40	5.000	100	4	RA4330S	450	1
300	63	5.000	100	4	RA4430S	500	1
300	80	5.000	125	4	RA4530S	500	1
300	100	5.000	125	4	RA4630S	500	1
300	125	5.000	125	4	RA4730S	500	1

Areas of application

Commercial or industrial installations where power electronics equipment is used or can be connected, such as:

- Frequency converters
- UPS systems
- Switched-mode power supplies
- High-frequency converters
- On-site power supply distribution boards
- Photovoltaic systems

AUXILIARY CONTACT

for all RCCBs

AUXILIARY CONTACT FOR ALL RCCBS

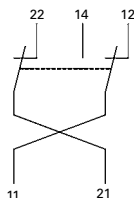

Auxiliary contact

MO	TYPE OF CONTACT	CONTACTS	ARTICLE NO.	WEIGHT g/EACH	PAKING UNIT
1/2	2 Auxiliary contacts (1 signal contact)	1 CO + 1 NC	RH11	45	1



1 switch – 2 functions

With the help of a CO contact, it is possible to switch between the signal contact and auxiliary contact functions.

Function

The RH11 can be retrofitted as an auxiliary contact or as a fault signal switch on an RCCB for all circuit breaker ranges, allowing for the display of an RCCB's operating state with the help of further output devices (buzzer, signal lamps etc.). The function setting is carried out with an actuator on the RH11.

Auxiliary contact

Switches when the RCCB is switched on and off
Correct function can be tested with a test button

Fault signal switch

Switches only when the RCCB trips (middle position)

Characteristics

- Can switch between auxiliary contact or fault signal switch function
- Can be retrofitted
- Small size (1/2 M)
- Settable
- 1 CO contact and 1 NC contact

Type of mounting

- Left of the RCCB with bracketing
- Any installation position

Areas of application

Operating state queries for electricity supplies for residential and single-purpose buildings as well as industrial plants.

Note

The auxiliary contact does not influence the RCCB.

Technical Data	Auxiliary contact and fault signal switch RH11
Rated voltage U_n	230 V AC / 110 V DC
Rated current I_n	6 A AC / 1 A DC
Switch contacts	1 x CO contact/ 1 x NC contact
Cross sections of connection lines	1 – 1.5 mm ²
Terminal screw torque	0.8 Nm

RESIDUAL CURRENT CIRCUIT BREAKERS · RP AND RW PRODUCT RANGE

RP (Type A) / RW (Type AC), Technical data

Technical data							
Characteristic	Type A (sensitive to pulsating current) / Type AC (sensitive to alternating current)						
Rated current I_n	16 A	25 A	40 A	63 A	80 A	100 A	125 A
Rated residual current $I_{\Delta n}$	0.01 A / 0.03 A / 0.1 A / 0.3 A / 0.5 A						
Surge current strength	0.5 μ s / 100 kHz / 200 A, ring-wave test						
Rated voltage U_n	230 V AC / 400 V AC						
Max. permissible operational voltage	$U_n + 10\%$						
Rated frequency	50 Hz						
Voltage operating area of the test equipment	2-pole: 100 V AC – 250 V AC / 4-pole: 185 V AC – 440 V AC						
Maximum tripping times	$1 \times I_{\Delta n} : \leq 300$ ms / $5 \times I_{\Delta n} : \leq 40$ ms						
Rated switching capacity I_m	500 A	500 A	500 A	800 A	800 A	1000 A	1250 A
Rated residual switching capacity $I_{\Delta m}$	500 A	500 A	500 A	800 A	800 A	1000 A	1250 A
Conditional rated short-circuit current I_{nc} 2-pole	10 kA						
Conditional rated residual short-circuit current $I_{\Delta c}$ 2-pole	10 kA						
Conditional rated short-circuit current I_{nc} 4-pole	10 kA						
Conditional rated residual short-circuit current $I_{\Delta c}$ 4-pole	10 kA						
Short-circuit back-up fuse	see table on page 60						
Power loss 2-pole 0,01 A (A, AC) / 0,03 A (AC)	1.5 W	3.5 W	8.0 W				
Power loss 2-pole 0,03 – 0,5 A	0.5 W	1.0 W	2.0 W	4.5 W	7.5 W	12 W	18 W
Power loss 4-pole 0,03 – 0,5 A	0.7 W	1.5 W	4.0 W	8.5 W	14 W	22 W	30 W
Installation position	any						
Degree of protection	IP20						
Resistance to mechanical shocks	20 g / 20 ms duration						
Vibration resistance	> 5g ($f \leq 80$ Hz, duration > 30 min)						
Ambient temperature range	- 25 °C to + 40 °C						
Climatic resistance	Acc. to DIN IEC 60068-2-30: Humid heat / cyclical (25 °C / 55 °C ; 93 % / 95 % rF)						
Cross sections of connection lines Circular conductor, solid Multiple wire Stranded wire	1 x 1.5 – 50 mm ² (1-conductor connection) / 2 x 1.5 – 16 mm ² (2-conductor connection) 1 x 1.5 – 50 mm ² (1-conductor connection) / 2 x 1.5 – 16 mm ² (2-conductor connection) 1 x 1.5 – 35 mm ² (1-conductor connection) / 2 x 1.5 – 16 mm ² (2-conductor connection)						
Terminal screw torque	3 Nm						
Minimum conductor cross section						50 mm ²	
Mechanical endurance	> 5,000 switching cycles						
Electrical endurance	> 2,000 switching cycles						
Building standards	DIN VDE 0664 T 10, EN 61008-1, IEC 61008-1						

Technical data	Differences in technical data to the RP/RW table above
Short-time delayed	
Surge current strength	3,000 A / lightning stroke current 8/20 μ s

Selective	
Rated current I_n	40 A, 63 A, 80 A, 100 A, 125 A
Rated residual current $I_{\Delta n}$	0.3 A
Surge current strength	5,000 A / lightning stroke current 8/20 μ s
Response delay	$1 \times I_{\Delta n}$: 130 ms < T \leq 500 ms / $5 \times I_{\Delta n}$: 50 ms < T \leq 150 ms

RESIDUAL CURRENT CIRCUIT BREAKERS · RA PRODUCT RANGE

RA (Type B), 4 pole, short-time delayed, selective, Technical data

Technical data						
Characteristic	Type B (sensitive to universal current)					
No. of poles	4					
Rated current I_n	25 A	40 A	63 A	80 A	100 A	125 A
Rated residual current $I_{\Delta n}$	0.03 A / 0.3 A / 0.5 A					
Tripping frequency range	Short-time delayed: 0 – 1 MHz / selective: 0 – 100 kHz					
Surge current strength	Short-time delayed: 3 kA / selective: 5 kA lightning impulse current 8/20 μ s					
Rated voltage U_n	230 V AC / 400 V AC					
Minimum operating voltage necessary for detecting residual currents of type A for detecting residual currents of type B	0 V (independent of mains voltage) ²⁾ 30 VAC					
Max. permissible operational voltage	$U_n + 10\%$					
Rated frequency	50 Hz					
Voltage operating area of the test equipment	185 V AC – 440 V AC					
Maximum tripping times	$1 \times I_{\Delta n} : \leq 300 \text{ ms}$ / $5 \times I_{\Delta n} : \leq 40 \text{ ms}$					
Response delay	$1 \times I_{\Delta n} : 130 \text{ ms} < T \leq 500 \text{ ms}$ / $5 \times I_{\Delta n} : 50 \text{ ms} < T \leq 150 \text{ ms}$					
Rated switching capacity I_m	500 A	500 A	800 A	800 A	1000 A	1250 A
Rated residual switching capacity $I_{\Delta m}$	500 A	500 A	800 A	800 A	1000 A	1250 A
Conditional rated short-circuit current I_{nc}	10 kA					
Conditional rated residual short-circuit current $I_{\Delta c}$	10 kA					
Short-circuit back-up fuse DIN VDE 0636 / IEC 60269-1	see table on page 60					
Power loss	1.5 W	4.0 W	8.5 W	14 W	22 W	30 W
Intrinsic consumption	max. 3.5 W					
Infeed side (res. current to 80 A) Infeed side (res. current 100/125 A)	Terminals 1, 3, 5, N ¹⁾ Terminals N, 3, 5, 7 ¹⁾					
Installation position	any					
Degree of protection	IP20					
Resistance to mechanical shocks	20 g / 20 ms duration					
Vibration resistance	$> 5g$ ($f \leq 80 \text{ Hz}$, duration $> 30 \text{ min}$)					
Ambient temperature range	$- 25 \text{ }^\circ\text{C}$ to $+ 40 \text{ }^\circ\text{C}$					
Climatic resistance	Acc. to DIN IEC 60068-2-30: Humid heat / cyclical ($25 \text{ }^\circ\text{C} / 55 \text{ }^\circ\text{C}$; 93 % / 95 % rH)					
Cross sections of connection lines Circular conductor, solid Multiple wire Stranded wire	$1 \times 1.5 - 50 \text{ mm}^2$ (1-conductor connection) / $2 \times 1.5 - 16 \text{ mm}^2$ (2-conductor connection) $1 \times 1.5 - 50 \text{ mm}^2$ (1-conductor connection) / $2 \times 1.5 - 16 \text{ mm}^2$ (2-conductor connection) $1 \times 1.5 - 35 \text{ mm}^2$ (1-conductor connection) / $2 \times 1.5 - 16 \text{ mm}^2$ (2-conductor connection)					
Terminal screw torque	3 Nm					
Minimum conductor cross section						50 mm ²
Mechanical endurance	$> 5,000$ switching cycles					
Electrical endurance	$> 2,000$ switching cycles					
Building standards	DIN VDE 0664 -10, E DIN VDE 0664-100					
Electromagnetic compatibility	VDE 0664-30, VDE 0839-6-2 (Interference resistance – industrial applications)					

1) Recommended for simple insulation tests on the system side, because in this way the internal overvoltage-protection elements can be disconnected from the load side of the system by switching off the B-type RCCB.

2) For supply voltages below 30 V AC, tripping caused by A and AC-type residual currents is guaranteed due to a function independent of mains voltage.

RCCBS · PRODUCT RANGES RP, RW AND RA

Short-circuit back-up fuses

PRODUCT RANGE		RATED CURRENT I_n [A]	RATED RESIDUAL CURRENT $I_{\Delta n}$ [A]	SHORT CIRCUIT BACK-UP FUSES SCPD [A]			
2-pole	A	16	0.01	50			
		25					
		40					
		16			0.03 - 0.5	100	
		25					
		40					
	63						
	AC	16	0.01	50			
		25					
		40					
		16			0.03 - 0.5	63	
		25					
40							
63							
4-pole	A, B	25	0.03 - 0.5	100			
		40					
		63					
		80					
		100					
		125					
	AC	16	16	0.01	50		
			25				
			16			0.03 - 0.5	63
			25				
			40				
			63				
80							
100		100	0.03 - 0.5	100			
		125					
		125			125	0.03 - 0.5	125
					100		
					125		
	100						
125							
100							

Rated short-circuit current I_{nc} = for all RCCBs = 10 kA

RESIDUAL CURRENT CIRCUIT BREAKERS

General explanations

General explanations regarding Residual Current Operated Protective Devices (RCDs)

Principle

A Residual Current operated protective Device – RCD for short – continuously calculates the sum of the instantaneous values of all currents that, via the active conductors, flow into an electrical system operated in an earthed AC network.

According to Kirchhoff's Current Law, this sum must always be zero. In the case of an insulation fault, the sum of these currents is not zero, because – depending on the fault impedance R_F and the earth resistance R_A – a residual current, also called differential current or residual current, does not flow back to the current source via the active conductors, but via the earth. If the effective value of the residual current exceeds the rated residual current $I_{\Delta n}$ of the RCD, the system is disconnected from the current source.

An auxiliary voltage source may be necessary to detect and assess the differential current, or it can be done independently of auxiliary voltage. In Germany, the term "residual current" is used when designating RCDs that detect and assess the residual current independently of auxiliary voltage, whereas the term "differential current" refers to detection and assessment depending on auxiliary voltage.

Protection in case of indirect contact by automatically disconnecting the power supply according to VDE 0100 - 410 (fault protection)

If – in the case of an insulation fault – earthed, conductive system parts which are not part of the operating circuit (e.g. enclosures of equipment of protection class I) have a voltage higher than the maximum permissible touch voltage U_{Lzul} , the system to be protected must be disconnected from the power supply quickly.

Earthing these parts with a sufficiently low earth resistance R_A allows for the touch voltage U_{Lzul} to cause a residual current to flow which activates an RCD and causes the system to be disconnected from the power supply immediately. To achieve this, the residual current must be higher than the rated residual current $I_{\Delta n}$ of the RCD.

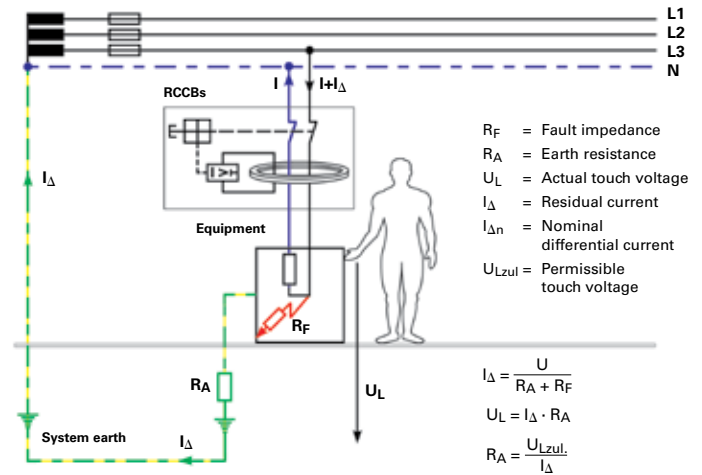

Figure 1

The maximum values for R_A for the maximum permissible touch voltages 25 V and 50 V can be found in the subsequent table. The resistance values for applications of up to $-25\text{ }^\circ\text{C}$ are reduced by a factor of 0.8, compared to the values for $-5\text{ }^\circ\text{C}$, because the response current I_{Δ} of the RCD at $-25\text{ }^\circ\text{C}$ may exceed the rated residual current $I_{\Delta n}$ by 25%.

RATED RESIDUAL CURRENT $I_{\Delta n}$ [A]	I_{min} , U_{Lzul}	$-5\text{ }^\circ\text{C}$ 25 V [Ω]	$-5\text{ }^\circ\text{C}$ 50 V [Ω]	$-25\text{ }^\circ\text{C}$ 25 V [Ω]	$-25\text{ }^\circ\text{C}$ 50 V [Ω]
0,01		2500	5000	2000	4000
0,03		830	1660	660	1330
0,30		83	166	60	130
0,50		50	100	40	80

Table 1

Highest permissible earth resistance R_A depending on the rated residual current $I_{\Delta n}$ and the touch voltage U_{Lzul} at a minimum ambient temperature T_{min} , of $-5\text{ }^\circ\text{C}$ / $-25\text{ }^\circ\text{C}$. All earth resistances must have half the value for systems with selective RCD sequences!

The interrelationships are illustrated in Figure 1.

RESIDUAL CURRENT CIRCUIT BREAKERS

General explanations

Additional protection in case of direct contact according to VDE 0100-410 (operator protection)

By using high-sensitivity RCDs with a rated residual current of $I_{\Delta n} \leq 30$ mA, additional protection in case of direct contact with an (unearthed) part conducting voltage is achieved (see Figure 2).

This additional protection is necessary if

- The insulation of totally-insulated devices or a feed cable is damaged,
- The protective conductor is interrupted,
- The protective and active conductor got mixed up and conductive parts which are normally earthed are thus energised, or
- There is contact with a part which is energised under normal operating conditions during repair work.

Based on this extended protection scope, the VDE set of standard specifications stipulates the use of a residual current circuit breaker according to VDE 0664-10 or an RCBO according

to VDE 0664-20 with $I_{\Delta n} \leq 30$ mA for the construction of systems in areas that are particularly accident-prone.

This applies to, for example,

- Outlet circuits in rooms with a bath tub or a shower (VDE 0100-701)
- Caravans, boats and yachts as well as their power supplies at camping sites or moorings (VDE 0100-721)
- Rooms used for medical purposes (VDE 0107).

By no means must this additional protection be considered a basic protection measure since the residual current flows through the human body into the earth in case of direct contact. It is rather an "emergency brake" for the fault events mentioned above. According to VDE 0100-530, only RCDs as described in the section "RCDs for fault protection, operator protection and fire protection" on the right side may be used for additional protection.

Fire protection

Effective protection against fires caused by earth faults can even be achieved with relatively insensitive RCDs ($I_{\Delta n} \leq 300$ mA). For earth residual currents ≤ 300 mA, the electric power transferred at the fault location is normally not sufficient to ignite standard flammable materials.

Although ignition is possible for higher residual currents because of the power, the RCD switches off the power supply in less than 0.3 seconds and thus limits the electric ignition power to harmless values.

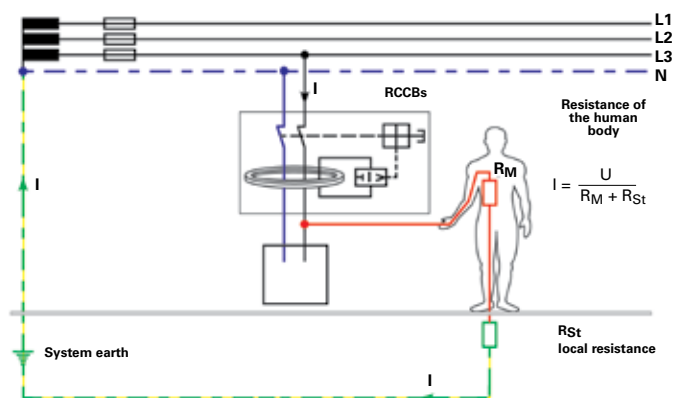

Figure 2

RCDs for fault protection, operator protection and fire protection

According to VDE 0100-530 (construction of non-voltage systems - part 530: selecting and setting up electrical equipment, switch-gears and control gears), the following RCDs can be used for the protection targets mentioned above:

- Residual current circuit breakers according to DIN EN 61008-1 VDE 0664-10 Abbreviation: **RCCB** (Residual **C**urrent **C**ircuit **B**reaker without integral overcurrent protection)
- RCBOs according to DIN EN 61009-1 VDE 0664-20 Abbreviation: **RCBO** (Residual **C**urrent Circuit **B**reaker with integral **O**vercurrent Protection)
- Circuit breakers with residual current trip according to DIN EN 60947-2 VDE 660-101 Appendix B Abbreviation: **CBR**

(Circuit **B**reaker providing **R**esidual current protection)

- **M**odular **R**esidual **C**urrent Protective **D**evis (abbreviation: **MRCD**) according to DIN EN 60947-2 VDE 0660-101 Appendix M whose units for measuring differential current (transformers), assessing differential current (differential current relays) and the load switch unit are accommodated in separated enclosures can be used in systems that are operated and, on a regular basis, maintained by people with electrotechnical expertise.
In systems where it is not possible to install the devices mentioned above – e.g. because an instant switch-off means endangering people or creating a lot of material damage – **RCM** differential current monitoring devices (abbreviation for **R**esidual **C**urrent **M**onitor) according to DIN EN 62020 VDE 0662 can be used.

RESIDUAL CURRENT CIRCUIT BREAKERS

Technical features and application notes

Tripping behaviour of the RCDs at different time sequences of the differential current



Only in systems whose equipment exclusively consists of linear or approximately linear electrical components – i.e. the flow of current is proportional to the voltage – can it be assumed that, in case of fault, only pure AC residual currents with the frequency of the mains voltage flow to the ground. These are components with ohmic, inductive or capacitive behaviour.

Even for sinusoidal supply voltages, equipment consisting of non-linear passive or active components such as rectifier diodes or quick switches like thyristors or transistors can cause currents that contain strong harmonics and/or whose mean values are not zero for the duration of one supply-frequency period, i.e. that have a DC component.

The residual current can also have a frequency differing from the supply frequency or consist of several partial currents with frequencies differing from the supply frequency. Therefore, RCDs with different technologies are also necessary to detect it.

The IEC 60755 technical report defines different types of RCDs as regards the time sequence of the residual currents which activate them.

This is illustrated in the following table.

RCD type	Sensitivity for differential/residual currents	Symbol
AC	Pure AC residual currents with low harmonic component i.e. sinusoidal residual currents whose mean value is zero over a period of mains frequency	
A	Residual currents of type AC and pulsating DC residual currents, whose inst. value is approx. zero ($< 6 \text{ mA}$) for the duration of at least a half period of the mains frequency	
B	Residual currents of type A (i.e. also AC) as well as smooth DC residual currents and AC residual currents with frequencies up to 1000 Hz	

The table on the following page (Figure 3) shows an arrangement of usual basic circuits of equipment with non-linear components (in short: electronic equipment, EE) and the time sequences of the resulting residual currents.

Just like the form of the current curve, the fundamental frequency of the residual current also has an influence on the response behaviour of the RCDs. Therefore, the response current and the response times are only within the range of the standardised values if the residual current frequency corresponds to the rated frequency of the RCDs.

For our standard devices, it is 50 Hz.

Area of application for A-type RCDs

After the previous explanations, it can be seen that, in case of an earth fault, AC-type RCDs are only activated within the stipulated limits if an approximately sinusoidal residual current is flowing i.e. current whose time mean value is zero and that does not show any excessive distortions (harmonic component $< 10\%$).

However, electronic components in similar circuits as illustrated in the table (Figure 3) on the next page are often used for modern equipment, e.g. to increase performance.

Thus, the time sequences of the possible residual currents are no longer sinusoidal, which means that, next to the supply frequency, there are also DC components and harmonics. Even a slight DC component of the residual current makes AC-type RCDs more insensitive or completely inefficient as regards measuring the AC component. AC-type RCDs can thus only offer sufficient protection in systems whose equipment contains exclusively passive linear components and in which any later connection of non-permitted equipment – e.g. via plug connections – can be excluded.

Due to this restricted protection scope, AC-type RCDs are no longer allowed to be used in Germany and several other western European countries.

Instead, A-type RCDs are usually installed nowadays because they are also properly activated by pulsating DC residual currents. Their function is exclusively based on the principle of induction, as is the case with AC-type RCDs. Thus, they only react to residual currents that cause a sufficient change of the magnetic flow in the converter core. To achieve this, a residual current must pulsate in such a way that its instantaneous value is equal to or almost zero ($\leq 6 \text{ mA}$) for at least half a supply-frequency period.

Therefore, A-type RCDs offer sufficient protection for electronic equipment with single-phase connection, except for EE with one-way rectifier and smoothing (Figure 3, circuit 2).

A-type RCDs do not react to residual currents with a high DC component or even smooth DC residual currents, as can be the case with EE with multi-phase connection (see circuits 3, 6 and 7 in Figure 3). Their intended function – reacting to A-type residual currents – even gets disturbed when there is smooth DC residual current at the same time.

Thus, according to EN 50178 / VDE 0160, EE that can create smooth DC residual currents must on no account be connected in system parts downstream of an A-type RCD.

If EE can cause residual currents with a high DC component ($\geq 6 \text{ mA}$), i.e. protection by an A-type RCD is not guaranteed, the manufacturer of the equipment must point out this fact in the operating instructions.

RESIDUAL CURRENT CIRCUIT BREAKERS

Technical features and application notes

Row	Basic circuit with fault location	Type of load current	Type of residual current	RCD tripping		
1	Single-phase 					
2	Single-phase with smoothing 					
3	Full-bridge circuit 					
4	Full-bridge circuit, half-controlled 					
5	Full-bridge circuit between external conductors 					
6	Three-phase star circuit 					
7	Three-phase full-bridge circuit 					
8	Generalised phase control 					
9	Burst control 					

Basic circuits of electronic equipment, time sequences of the load and residual currents as well as RCDs suitable for standard tripping

Figure 3

Source:
E DIN VDE 0100-530; Appendix B

RESIDUAL CURRENT CIRCUIT BREAKERS

Technical features and application notes

Area of application of B-type RCDs

If equipment according to the circuits 2, 6 and 7 in Figure 3 (see previous page) can cause smooth DC residual current which is not detected by an A-type RCD, the manufacturer of the equipment must – under the terms of EN 50178 / VDE 0160 – point out that it is necessary to use a B-type RCD. This applies to almost all equipment of power electronics (EE) if it is operated in earthed networks without galvanic isolation in a three-phase manner, such as frequency converters, bigger UPS systems, welding inverters etc.

Such equipment usually delivers output voltage in the form of bipolar pulse-width modulated square-wave pulses with pulse frequencies in the range of 1 kHz up to several tens of kHz. For frequency converters, the resulting load current then has a sinusoidal shape – as a result of the inductance of the motors connected – with the desired adjusted motor frequency. Earth faults, however, normally display an ohmic resistance behaviour. That is why the output voltage of a frequency converter creates pulse-width modulated rectangular residual currents with the pulse frequency.

This means that for such applications, a RCD must also react to residual currents with the pulse frequency and their harmonics (3rd and 5th harmonic) to offer comprehensive protection. The response threshold must not exceed the maximum values permitted for a certain protection level (fault protection, fire protection or operator protection) for the whole frequency range.

Unfortunately, the current device standards do not pay the necessary attention to this point yet. The German VDE 0664-100 standard only offers details about the detection of residual current of up to 2 kHz and the international set of standard specifications IEC 60755 and the future IEC 62423 only require a residual current sensitivity of up to 1 kHz. For these upper frequencies, residual current response thresholds of up to approx. 20 or 10 times the rated residual current are still allowed. However, for fire protection, for example, it would be necessary to have a response frequency range of up to at least 100 kHz with an upper response threshold of a maximum of 0.3 A.

Operational drainage currents with very different frequencies constantly flowing to the ground from equipment via suppressor capacitors, for example, are a serious problem that often makes the use of RCDs difficult. If they are high enough, they can undesirably activate a B-type RCD if it detects the residual current via a broad frequency range with high sensitivity. False tripping can often be avoided by selecting the RCDs with respect to their response-current frequency response and the rated residual current.

By choosing the equipment, it is, however, recommended to guarantee even while planning the system that the sum of the

drainage currents does not exceed the lower response threshold of the RCDs and thus false tripping can be excluded. For this purpose, we specify the frequency response of the response current for all device types in the catalogue texts of our various RCDs with tripping characteristic B.

Designs with increased surge current strength (K type)

Pulse-shaped overvoltages caused by switching operations or thunderstorms can trigger discharge currents via the capacitance of the equipment to the ground or the interconnect capacitance resulting in undelayed RCDs being activated occasionally. Equipment with a high capacitance to the ground due to either the extensive dimensions of live parts or suppressor capacitors connected to the ground is critical in this regard.

Among the loads mentioned first are, for example, electrical panel heating and fluorescent lamps in big quantities (> 20 units per current path) with conventional ballasts.

The equipment mentioned second includes, amongst others, fluorescent lamps with electronic ballasts, X-ray equipment and computer systems. The use of our RCDs with increased surge current strength (for K-type RCCBs) is recommended to guarantee reliable operation without false switch-off even in these especially critical cases.

These devices are largely resistant to surge residual currents because of a special design of the residual current detection and assessment unit.

Testing the surge current strength is normally carried out by means of the standardised lightning stroke current 8/20 according to IEC 60060-1.

There, the peak value of the highest current surge that can flow through the RCD transformer in both directions and via all current paths without causing tripping is used as a measurement.

The surge current strength of our standard RCCBs and RCBOs is > 200 A.

The following figure on the next page shows the tripping times of an RCCB responding in an undelayed and in a delayed (selective) manner.

RESIDUAL CURRENT CIRCUIT BREAKERS

Technical features and application notes

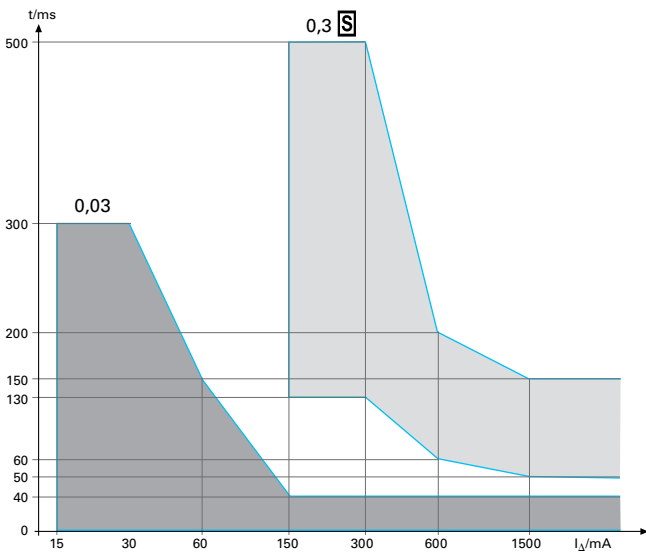

Tripping times of an RCCB responding in an undelayed and in a delayed (selective) manner

Selectivity

Selective RCDs only react to the occurrence of residual current after a current flow duration of several supply-frequency periods. This makes selective tripping possible if, for example, two RCD residual current circuit breakers are connected in series, i.e. even for high residual currents, only that RCD in whose downstream system part the earth fault occurs reacts in the event of fault.

The figure below makes this correlation clear.

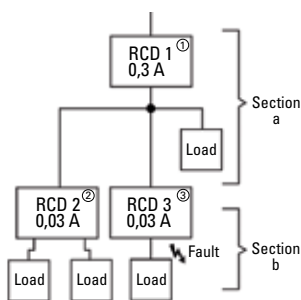

Selective tripping if two RCDs for sequenced residual current protection are connected in series

If an undelayed RCD was used instead of an RCD 1, every residual current $I_{\Delta} > 0.3 \text{ A}$ in system part b would trip both RCD 1 and RCD 3.

Only the response delay of the selective RCD 1 ensures that only RCD 3 responds.

The response time of both selective and normal RCDs can depend on the amount and type of the residual current. The above figure (tripping times) gives an example of a normal residual current circuit breaker with $I_{\Delta n} = 30 \text{ mA}$ and a selective circuit breaker with $I_{\Delta n} = 300 \text{ mA}$ to illustrate this.

The rated residual current of the delayed RCD must, compared to the undelayed RCD, be chosen at least one level higher to ensure selectivity in any case (i.e. also for small residual currents). In a system with selective sequences, the earth resistance R_A must not be any greater than half the value to be found in table 1 (see page 59).

In the event of fault, this enables a residual current with twice the value of the rated residual current to flow without the permitted touch voltage U_{LZUL} being exceeded so that also the delayed RCCB is activated within a period of $< 300 \text{ ms}$.

Selective RCCBs have a surge current strength of $> 5 \text{ kA}$.

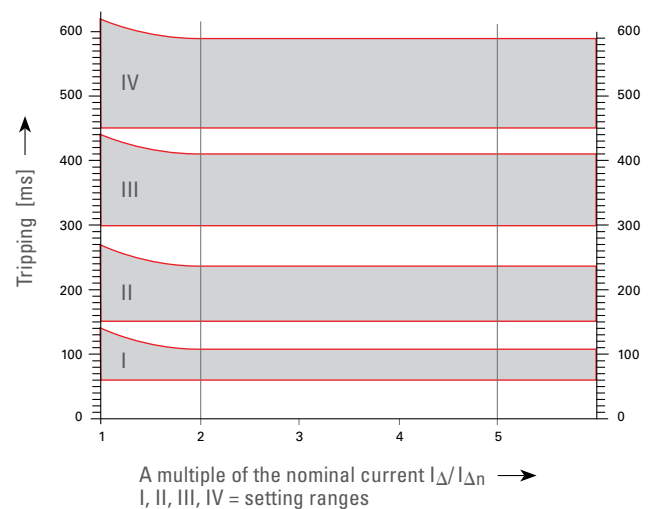
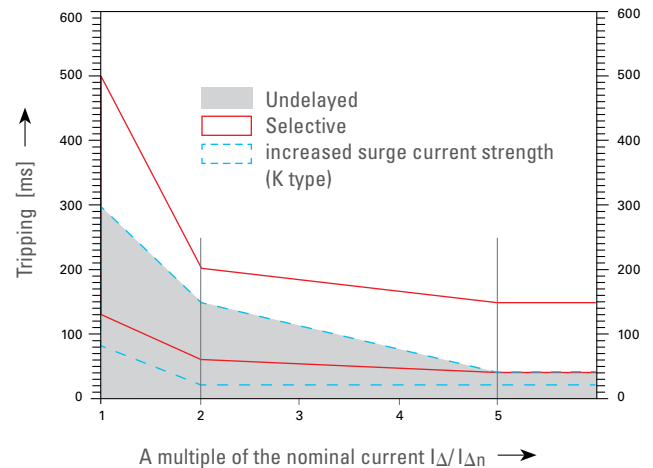

Total tripping times for undelayed and delayed RCCBs

RESIDUAL CURRENT CIRCUIT BREAKERS

Technical features and application notes

Tripping times

The figure "tripping times" on the previous page shows the tripping times of our RCCBs and CBRs depending on a multiple of the rated residual current. From this, the tripping times for circuit breakers of all rated residual currents can be determined for every desired residual current value.

Voltage dependence

A RCD independent of the mains voltage e.g. in the form of a conventional residual current circuit breaker (RCCB) takes the energy necessary for tripping only from the earth residual current.

Even if the mains voltage drops or the neutral is disconnected, a RCCB is still functional. Even longer periods of overvoltage as a result of system disturbances have no impact on the tripping function of a residual current circuit breaker. Because of this high degree of operational reliability, a residual current circuit breaker is always to be preferred to a residual current operated protective device depending on the mains voltage.

In German systems that are not operated by personnel with technical expertise and not subject to regular maintenance carried out by experts, the basic protection measure "protection by automatic power-supply cut-off" in compliance with VDE 0100-410 must therefore only be realised with RCDs that are independent of auxiliary voltage.

Our residual current circuit breakers meet the requirement of mains voltage independence.

Our RA4xxx RCCBs, sensitive to universal current, can also be considered independent of mains voltage in terms of the DIN EN 61008-1 VDE 0664-10 standard, because they react to A-type residual currents even in the case of loss of the mains voltage, i.e. if two phases and the neutral are interrupted.

These devices only require a very little amount of auxiliary voltage, namely 30 V AC, for tripping with smooth DC residual currents and residual currents whose frequency differs from the supply frequency. This value is below the touch voltage of 50 V permitted in normal installations. Thus, the requirement of the VDE 0664-100 and even more that of the future international IEC 62423 standard is more than fulfilled.

Ambient temperature

In almost all international standards, the normal ambient temperature range for RCDs is $-5\text{ }^{\circ}\text{C}$ to $+35\text{ }^{\circ}\text{C}$ with short-term temperatures of up to $40\text{ }^{\circ}\text{C}$ for a maximum of 1h in 24h.

Generally, our RCDs are upgraded for low temperatures of down to $-25\text{ }^{\circ}\text{C}$. This quality is indicated by the  symbol on the nameplate of the devices.

If these RCDs are to work at temperatures below $-5\text{ }^{\circ}\text{C}$, all

international standards grant a tripping current which is 25 % higher. The earth resistance must thus be reduced to 80 % – compared to applications at temperatures down to $-5\text{ }^{\circ}\text{C}$ – to still achieve tripping at a touch voltage of $\leq 50\text{ V} / \leq 25\text{ V}$.

Short-circuit strength

RCDs must be protected against short circuits and, if it appears to be necessary, against overloading by means of suitable protection devices. The maximum prospective short-circuit current in connection with the maximum permissible back-up fuse (according to VDE 0636 utilisation category gL) is specified for our RCCBs in the data tables.

On the nameplate of the RCCB, the  symbol, for example, indicates that, in connection with a back-up fuse of 63 A, the circuit-breaker sustains a prospective short-circuit current of 10 kA.

Our RCCBs for nominal currents of up to 63 A are sufficiently protected against short circuits by a back-up fuse of 63 A. In most cases, this guarantees a short-circuit current even through the service fuse (max. 63 A).

Please note that a short-circuit fuse does not automatically guarantee overload protection.

Overload must be excluded by system planning taking simultaneity factors into account.

Installation notes

Mounting

Our RCDs can be used in any position. With the exception of B-type RCCBs, the infeed and load side are not defined either. 4-pole devices can also be used for 2 and 3-pole operation. Here, the voltage supply of the test equipment must be taken into account.

Mounting is carried out on DIN-rails according to DIN EN 60715. The IP40 degree of protection that can be achieved with accurate terminal covers only guarantees touch protection and limited protection against solid foreign bodies. Without additional housing, the RCDs can thus only be used in dry and dust-free rooms.

We recommend additional housing of the IP54 degree of protection for the use in rooms that are occasionally wet or in spots with increased dirt accumulation.

RESIDUAL CURRENT CIRCUIT BREAKERS

Technical features and application notes

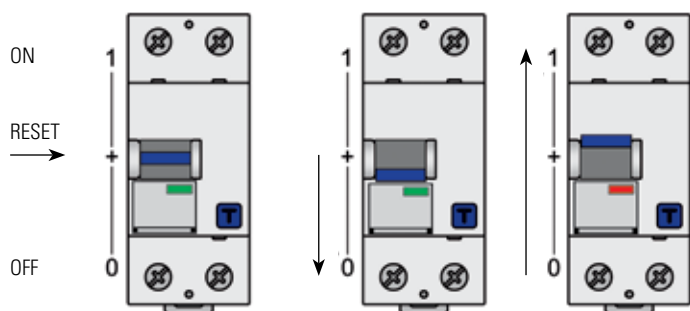

Reset function

The switching knob is equipped with a so-called reset function.



Residual current circuit breaker in centre position

It tripped due to a fault in the circuit. It is of utmost importance that any possible causes be checked before switching on again.



Residual current circuit breaker in 0 position

It was switched off manually.

Informed at a glance

On the basis of the switching knob position, it can be seen if the residual current circuit breaker was switched off by a fault (**knob is in the centre position**) or manually (**knob is in the 0 position**).

Important note:

For your own safety, the knob must be moved from the centre position to the 0 position to eliminate the fault. Only then can the residual current circuit breaker be switched on again!

Connecting and testing

Feed all conductors necessary for the operation of the system (also the neutral) through the RCCB.

Make sure all conductors are well insulated against the ground (test with insulation resistance meter). Earth the equipment to be protected. Try not to use the neutral connected upstream of the RCCB as a protective conductor (danger when neutral is interrupted before the branch point, e.g. in overhead systems). Before start-up, not only check the RCCB for correct functioning, but also the whole protective circuit (measure earth resistance and detect maximum possible touch voltage for residual currents at the tripping limit of the RCCB).

The residual current circuit breakers must be checked every six months to guarantee their smooth mechanical functioning.

Quality characteristics

- The metal parts of the switching mechanism are made of rust-proof material
- All devices meet the requirements of the RoHS guideline, which means that all plastics used are bromine-free and halogen-free, the metal parts do not contain lead or cadmium
- All materials used are recyclable
- All electrical data is tested several times during extensive final tests and permanently allocated to every device and archived.

RESIDUAL CURRENT OPERATED CIRCUIT BREAKER WITH OVERCURRENT PROTECTION

sensitive to pulsating currents, Type A acc. to IEC 61009

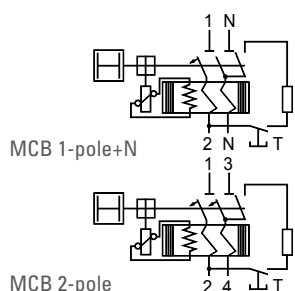

RCBOs offer a compact possibility of implementing wiring protection and protection against personal injury in one device. The RCBO protects itself through its CB part against overload. An undesired overload due to too-high load currents is not possible.

One RCBO is assigned to every circuit. So the full residual current is available to every circuit as drainage current. For one residual current in a circuit, only the affected circuit is switched off.



RATED CURRENT I_n A	RATED RESID. CURRENT $I_{\Delta n}$ mA	CHARACTERISTIC		MODULES	WEIGHT g/EACH	PACKING UNIT
		B ARTICLE NO.	C ARTICLE NO.			

Short circuit withstand rating 10 kA						
MCB 1-pole + N						
6	10	RB0601	RC0601	2	225	1
6	30	RB0603	RC0603	2	225	1
6	100	RB0610	RC0610	2	225	1
6	300	RB0630	RC0630	2	225	1
6	500	RB0650	RC0650	2	225	1
10	10	RB1001	RC1001	2	225	1
10	30	RB1003	RC1003	2	225	1
10	100	RB1010	RC1010	2	225	1
10	300	RB1030	RC1030	2	225	1
10	500	RB1050	RC1050	2	225	1
13	30	RB1303		2	225	1
16	10	RB1601	RC1601	2	225	1
16	30	RB1603	RC1603	2	225	1
16	100	RB1610	RC1610	2	225	1
16	300	RB1630	RC1630	2	225	1
16	500	RB1650	RC1650	2	225	1
20	10	RB2001	RC2001	2	225	1
20	30	RB2003	RC2003	2	225	1
20	100	RB2010	RC2010	2	225	1
20	300	RB2030	RC2030	2	225	1
20	500	RB2050	RC2050	2	225	1
25	10	RB2501	RC2501	2	225	1
25	30	RB2503	RC2503	2	225	1
25	100	RB2510	RC2510	2	225	1
25	300	RB2530	RC2530	2	225	1
25	500	RB2550	RC2550	2	225	1
32	30	RB3203	RC3203	2	225	1
32	100	RB3210	RC3210	2	225	1
32	300	RB3230	RC3230	2	225	1
32	500	RB3250	RC3250	2	225	1
40	30	RB4003	RC4003	2	225	1
40	100	RB4010	RC4010	2	225	1
40	300	RB4030	RC4030	2	225	1
40	500	RB4050	RC4050	2	225	1

Short circuit withstand rating 10 kA						
MCB 2-pole						
10	30	RB1003N		3	335	1
13	30	RB1303N		3	335	1
16	30	RB1603N	RC1603N	3	335	1

RESIDUAL CURRENT OPERATED CIRCUIT BREAKER WITH OVERCURRENT PROTECTION

Accessories and Busbars



Auxiliary contact

Rated voltage U_e 230V AC
 Rated operating current I_e
 at AC-14 for U_e 400V AC 3.5 A
 at AC-14 for U_e 230V AC 6.5 A
 at DC-13 for U_e 110/220V UC 0.5/0.25 A
 at DC-13 for U_e 24V UC 16 A
 Rated current I_{th} 16 A

	ARTICLE NO.	WEIGHT g/EACH	PACKING UNIT
--	-------------	---------------	--------------

1 CO	RLH1W	50	1
------	-------	----	---



CROSS SECTION (mm ²)	BUSBAR CURRENT START OF BUSBAR/MIDDLE INFEEED	MODULES +H (AUXILIARY CONTACT)	PHASES	ARTICLE NO.	WEIGHT g/EACH	PACKING UNIT	SUITABLE END CAP ARTICLE NO.
----------------------------------	---	--------------------------------	--------	-------------	---------------	--------------	------------------------------

Busbars fork type for RCBOs 2 M

2-phase and 1-phase + N

10	63/110	28/2	2/1+N	SB26010	390	20	SB.A5
16	80/130	28/2	2/1+N	SB26016	430	20	SB.A2

2-phase / 1-phase + N and auxiliary contact

16	80/130	22/2+H	2/1+N	SB26216	470	20	SB.A2
----	--------	--------	-------	---------	-----	----	-------

3-phase + N, L1/N, L2/N, L3/N

16	80/130	27/2	3+N	SB41627	725	15	SB.A3
----	--------	------	-----	---------	-----	----	-------

Busbars fork type for RCBOs 3 M

3-phase + N, L1/N, L2/N, L3/N

16	80/130	18/3	3+N	SB41618	650	5	SB.A3
----	--------	------	-----	---------	-----	---	-------

Busbars fork type for RCBOs 2 M

3-phase + N, L1/N, L2/N, L3/N

16	80/130	6/2	3+N	G41606	135	20	-
----	--------	-----	-----	--------	-----	----	---



Busbars cannot be cut to length!

RESIDUAL CURRENT OPERATED CIRCUIT BREAKER WITH OVERCURRENT PROTECTION

Technical data

RCBO	
Rated voltage U_n	230 V
Rated residual current $I_{\Delta n}$ [mA]	10, 30, 100, 300 und 500
RCCB type	sensitive to alternating current Type AC
Rated current I_n [A]	6, 10, 13, 16, 20, 25, 32 und 40
Function limit for functions of the test equipment	AC 100 V
Short circuit withstand rating I_{cn} (according to DIN EN 61009)	10 kA
Energy limiting class	3
Frequency	50 Hz
Number of poles	LS 1-pole+N (2 M), LS 2-pole (3 M)
Installation position	any
Degree of protection	IP 20
Connecting terminals	Both-sided multi-function terminal For simultaneous connection of conductors and pin rails
Terminal screws	± and Pozidriv 2
Torque	2 Nm
Conductor cross sections	1.5 to 25 mm ²
Mechanical endurance	10,000 switching cycles (10,000 ON/10,000 OFF)
Electrical endurance	4,000 switching cycles (4,000 ON/4,000 OFF)
Standard	DIN VDE 0664-T100, EN 61009, IEC 61009

Thermal trip and short circuit trip circuit breaker			
Characteristic		B	C
Test currents	Thermal not tripping I_1 (A) > 1 h	$1.13 \times I_n$	$1.13 \times I_n$
	Thermal tripping I_2 (A) < 1 h	$1.45 \times I_n$	$1.45 \times I_n$
	Electromagnetic not tripping I_4 (A) > 0.1 s	$3 \times I_n$	$5 \times I_n$
	Electromagnetic tripping I_5 (A) < 0.1 s	$5 \times I_n$	$10 \times I_n$

RESIDUAL CURRENT OPERATED CIRCUIT BREAKER WITH OVERCURRENT PROTECTION

Technical data

Short circuit selectivity to fuses in kA										
RCBO 10 kA										
Characteristic	Rated current I_n (A)									
	B	6	10	13	16	20	25	32	40	
C		6	10	13	16	20	25	32	40	
I_n (A)	16									1.)
Fuse according to DIN VDE 0636 operating class	20	0,5	0,5	0,5						
		0,5	0,5	0,5						
	25	0,8	0,7	0,6	0,6	0,5				
		0,8	0,7	0,6	0,6	0,5				
	35	1,1	0,9	0,8	0,8	0,7	0,7			
		1	0,8	0,8	0,8	0,7	0,7			
	50	2,5	2,1	2,0	1,9	1,8	1,8	1,7		
		2,3	1,9	1,8	1,7	1,6	1,5	1,4		
63	5	2,7	2,6	2,5	2,4	2,3	2,2	2,1	2	
	3	2,6	2,5	2,4	2,3	2,2	2,1	2,1	2	
80	8	5	4,2	4,2	3,8	3,6	3,4	3,3	3,2	
	8	5	4,2	4,2	3,8	3,6	3,4	3,3	3,2	
100	10	8,5	7	6,5	6,1	5,8	5,3	5,1	4,8	
	10	8,5	7	6,5	6,1	5,8	5,3	5,1	4,8	

1.) There is no more overload selectivity above the step line.

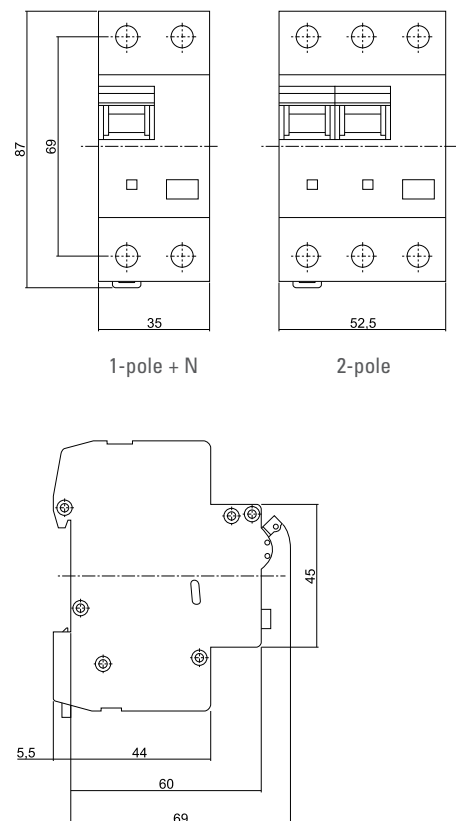
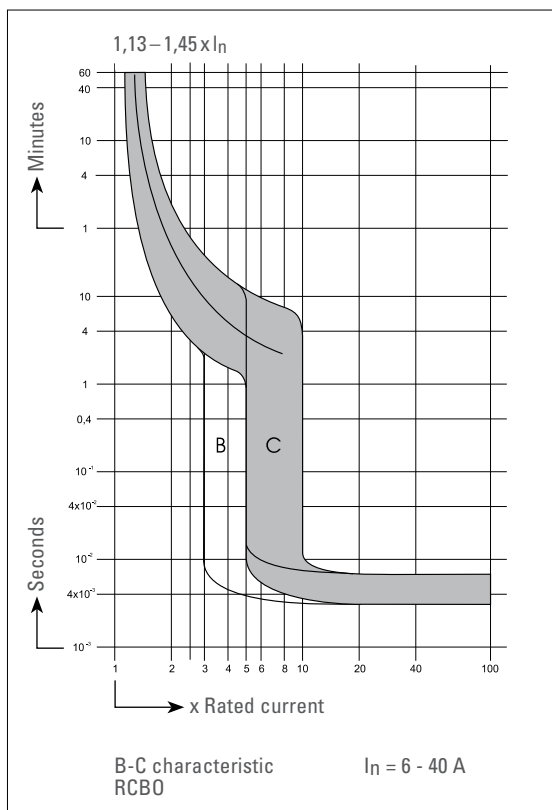



ABL SURSUM
LOMo 852

CE

100-280V
47-80Hz
0.25A (RDA)

ON
OFF

11 M 21 M 31 M 41 M 51 M 61 M
A1 21 31 41 51 61

TTY
E1 E2 E3 E4 E5 E6 E7 E8 E9
RC RC RC RC RC RC RC RC RC

0141001
L10010
002500

SWITCHING DEVICES

DIN-RAIL PANEL PRODUCTS

Switches	72
Buttons	73
Light Signals	73
SCHUKO socket outlet	73
Installation relays mechanical	74
Storage relays mechanical	74
Electronic control relays	76
Mechanical remote switches	78
Remote switch central electronic control	80
Touch dimmer	82
Load shedding relays	83
Twilight switch	84
Time relays and multi-function time relays	85
Mains monitoring	88
Installation contactors	89
Stairway light time switches	93
Synchronised / Quartz time switch	95
Digital timer	96
Transformers	97
LOMO Logic Module	98

DIN-RAIL PANEL PRODUCTS

Switches



ON/OFF SWITCH 1-POLE
16 A 250 V~

1 M

	ARTICLE NO.	WEIGHT g/ EACH	PACKING UNIT
1NO	AS161	55	12

AS161

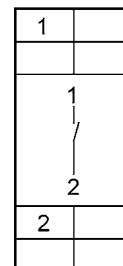

ON/OFF SWITCH 1-POLE
WITH LIGHT SIGNAL
16 A 250 V~

1 M

	ARTICLE NO.	WEIGHT g/ EACH	PACKING UNIT
1NO	ASL161	55	12

ASL161

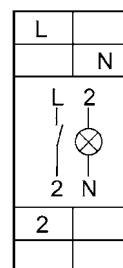

GROUP SWITCH 1-POLE
16 A 250 V~
Autom.-Off-Manual

1 M

	ARTICLE NO.	WEIGHT g/ EACH	PACKING UNIT
1CO	GS161	55	12

GS161

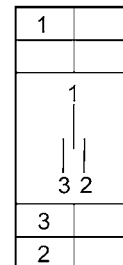

CO SWITCH 1-POLE
16 A 250 V~

1 M

	ARTICLE NO.	WEIGHT g/ EACH	PACKING UNIT
1CO	WS161	55	12

WS161

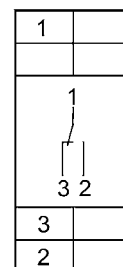

DIN-RAIL PANEL PRODUCTS

Button, light signals and SCHUKO socket outlet



MOMENTARY-CONTACT SWITCH
16 A 250 V~

1 M

	ARTICLE NO.	WEIGHT g / EACH	PACKING UNIT
--	-------------	-----------------	--------------

1CO	WT161	55	12
-----	--------------	----	----

WT161

1	
	1
	3 2
3	
2	



LIGHT SIGNAL 230 V UC

1 M

	ARTICLE NO.	WEIGHT g / EACH	PACKING UNIT
--	-------------	-----------------	--------------

Clear	RST230	73	12
Red	RSR230	73	12
Blue	RSB230	73	12
Green	RSG230	73	12
Yellow	RSY230	73	12



ON/OFF SWITCH 3-POLE 415 V~

Incoming circuit breaker for circuit distribution board, lockable in the "ON" or "OFF" position, maximum connection cross section 25 mm²

3 M

RATED CURRENT	ARTICLE NO.	WEIGHT g / EACH	PACKING UNIT
---------------	-------------	-----------------	--------------

63 A	AS63	200	4
100 A	AS100	200	4



SCHUKO SOCKET OUTLET 
10/16 A 250 V~

2.5 M

	ARTICLE NO.	WEIGHT g / EACH	PACKING UNIT
--	-------------	-----------------	--------------

	SD230	110	4
--	--------------	-----	---

DIN-RAIL PANEL PRODUCTS

Installation relays / storage relays mechanical



INSTALLATION RELAY
16 A 250 V~
1-pole 1NO

1 M

	ARTICLE NO.	WEIGHT g/EACH	PACKING UNIT
12 V~	IR01210	99	12
230 V~	IR23010	99	12

12 V~	IR01210	99	12
230 V~	IR23010	99	12

IR...10

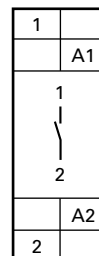

INSTALLATION RELAY
16 A 250 V~
2-pole 2NO

1 M

	ARTICLE NO.	WEIGHT g/EACH	PACKING UNIT
230 V~	IR23020	104	12

230 V~	IR23020	104	12
--------	---------	-----	----

IR...20

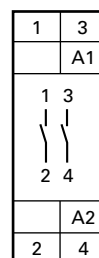

INSTALLATION RELAY
16 A 250 V~
2-pole 1NO + 1NC

1 M

	ARTICLE NO.	WEIGHT g/EACH	PACKING UNIT
230 V~	IR23011	106	12

230 V~	IR23011	106	12
--------	---------	-----	----

IR...11



STORAGE RELAY
sealable
16 A 250 V~
1 CO contact

1 M

	ARTICLE NO.	WEIGHT g/EACH	PACKING UNIT
230 V~	SP2301W	85	12

230 V~	SP2301W	85	12
--------	---------	----	----

SP2301W

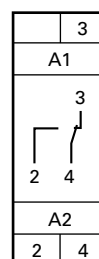

DIN-RAIL PANEL PRODUCTS

Installation relays / storage relays mechanical

Installation relay / Storage relay mechanical		
Technical data / type	IR	SP2301W
Contact material	AgSnO ₂	
Contact interval	3 mm / 2 mm	
Interval control connections / contact	> 6 mm	
Test voltage contact / contact contact / magnet system	2000 V 4000 V	
Nominal switching capacity AC 250 V, 400 V	16 A, 10 A / 10 A, 6 A	16 A / 250 V 3520 VA
Incandescent lamps and halogen lamp load 230 V	10 A (2300 W)	
Fluorescent lamp load in DUO switching	16 A (3500 W) / 10 A (2000 W)	
Fluorescent lamp load inductive or capacitive	10 A (1300 W)	
Electronic ballasts	I_{ON} 140 A 10 ms / 70 A 10 ms ¹⁾	
Fluorescent lamp load compensated in parallel	4 A (500 W)	
Inductive load $\cos \varphi = 0.6$ / 230 V AC	10 A (1300 W)	
High-pressure mercury lamp and metal halide lamp, uncompensated	500 W	
Contact load DC max.	100 W	
Mechanical endurance, change of position 10 ³ / h	>10 ⁶	>10 x 10 ⁸
Endurance with rated load, $\cos \varphi = 1$ and 10 ³ / h	>10 ⁵	
Endurance with incandescent lamps 1000 W and 10 ³ / h	>10 ⁵	
Endurance with rated load, $\cos \varphi = 0.6$ und 10 ³ / h	>4 x 10 ⁴	
Switching frequency max.	10 ³ / h	10 ⁴ / h
Closing delay	10 - 20 ms	10 ms
Opening delay	5 - 15 ms	5 ms
Switch position display	per contact	Light emitting diode
Manual operation	yes	no
Switch-on duration	100% ²⁾	100%
Temperature at the installation location max. / min.	+50° / -5 °C	+40 °C
Control voltage range	0.9 to 1.1 x U _n	0.95 to 1.06 x U _n
Coil power loss AC + DC ± 20 %	1- and 2-pole 2 W	1.9 W
Total power loss when continually excited	1-pole 4 W	1.9 W
Rated voltage and rated contact load	2-pole 6 W	
Max. parallel capacitance (length) of the control line	0.06 µF (200 m)	
Max. induction voltage at the control inputs	0.2 x U _n	

1) For electronic ballasts, a switch-on current 40 times more powerful is to be expected.

2) Should several remote switches and installation relays be under continuous excitation, please make sure that there is sufficient ventilation in accordance with the power loss calculation and additionally that a ventilation interval of approx. ½ modules is observed.

Function description:

IR = Installation relay
SP = Storage relay

Type key

e.g. installation relay
article no. IR23011

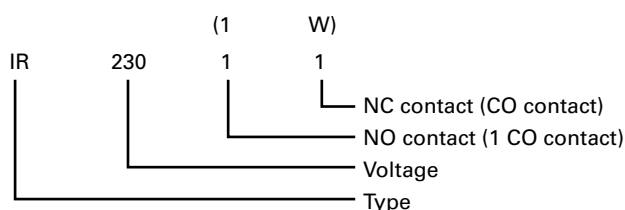

DIN-RAIL PANEL PRODUCTS

Electronic control relays



CONTROL RELAYS
 10 A / 250 V
 1 CO contact
 Universal control voltage
 8 – 230 V

1 M

	ARTICLE NO.	WEIGHT g/EACH	PACKING UNIT
8 to 230 V UC	STU1W	58	1

8 to 230 V UC	STU1W	58	1
---------------	-------	----	---

STU1W

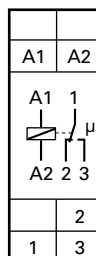

Bistable relay contact

After installation, the mains voltage must first be applied to the relay so that the switching contacts can go into a defined state. After about 2 seconds, the switched load can be connected to the mains.



CONTROL RELAYS
 10 A / 250 V
 2 CO contacts
 Universal control voltage
 8 – 230 V

1 M

	ARTICLE NO.	WEIGHT g/EACH	PACKING UNIT
8 to 230 V UC	STU2W	74	1

8 to 230 V UC	STU2W	74	1
---------------	-------	----	---

STU2W

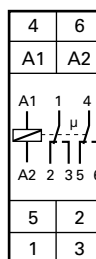

Bistable relay contact

After installation, the mains voltage must first be applied to the relay so that the switching contacts can go into a defined state. After about 2 seconds, the switched load can be connected to the mains.

DIN-RAIL PANEL PRODUCTS

Electronic control relays

Electronic control relays	
Technical data / type	STU1W / STU2W
Contacts	
Contact material / Contact interval	AgSnO ₂ / 0.5 mm
Interval control connections / contact	< 6mm
Interval control connections C1-C2 / contact	
Test voltage contact / contact	1000 V
Test voltage control connections / contact	4000V
Nominal switching capacity AC	10A / 250V
Incandescent lamps and halogen lamp load 230 V for lamps with max. 200 W	1000 W
Fluorescent lamp load in DUO switching	1000 W
Fluorescent lamp load inductive or capacitive	1000 W
Fluorescent lamp load compensated in parallel	4 A; 500 W
High-pressure mercury lamp and metal halide lamp, uncompensated	–
Electronic ballasts	I_{VV} max. 70A /10ms ¹⁾
Inductive load $\cos \varphi = 0.6$ / 230 V AC	5 A, 650 W
Max. switching current DC1: 12 V / 24 V DC	8 A
Endurance with rated load, $\cos \varphi = 1$ or incandescent lamps 1,000 W at 100 / h	> 10 ⁵
Endurance for rated load, $\cos \varphi = 0.6$ und 100 / h	> 4 x 10 ⁴
Switching frequency max.	10 ⁴ / h
Closing delay	5 - 10 ms
Opening delay	5 - 10 ms
Switch position display	Light emitting diode
Box terminal cross section	12 mm ²
Maximum cross section of a conductor	6 mm ²
Screw heads slotted/cross slot	pozidriv
Protection cover (device side)	DIN EN 50274, VDE 0660-514 BGV A3
Electronics	
Switch-on duration	100%
Temperature at the installation location max. / min.	+50 °C / -20 °C
Minimum command duration / control voltage area	50 ms / 0.9 to 1.1 x U _n
Coil power loss AC+DC ± 20%	1U 0.5 W, 2U 0.8 W
Control current	12 V UC: 90 mA ²⁾
	230 V UC 20 mA ²⁾
Max. parallel capacity (length) of the control line	0.06 µF (approx. 200 m)

Fulfilled EN 61000-6-3, EN 61000-6-1 and EN 60669 standards

1) For electronic ballasts, a switch-on current 40 times more powerful is to be expected

2) Control relays STU1W and STU2W are clocked. From this, currents of up to 1 A result in the µs range.

DIN-RAIL PANEL PRODUCTS

Mechanical remote switches



REMOTE SWITCH

16 A 250 V~

1-pole 1NO

1 M

	ARTICLE NO.	WEIGHT g / EACH	PACKING UNIT
12 V~	FS01210	96	12
230 V~	FS23010	96	12

12 V~	FS01210	96	12
230 V~	FS23010	96	12

FS...10

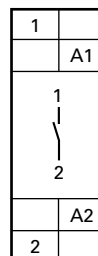

REMOTE SWITCH

16 A 250 V~

2-pole 2NO

1 M

	ARTICLE NO.	WEIGHT g / EACH	PACKING UNIT
230 V~	FS23020	107	12

230 V~	FS23020	107	12
--------	----------------	-----	----

FS...20

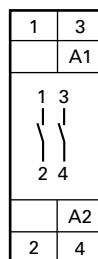

REMOTE SWITCH

16 A 250 V~

2-pole 1NO + 1NC

1 M

	ARTICLE NO.	WEIGHT g / EACH	PACKING UNIT
230 V~	FS23011	107	12

230 V~	FS23011	107	12
--------	----------------	-----	----

FS...11

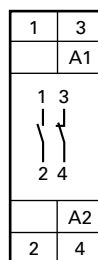

DIN-RAIL PANEL PRODUCTS

Mechanical remote switches

Mechanical remote switches	
Technical data / type	FS
Contact material	Ag Sn O ₂
Contact interval	3 mm / 2 mm
Interval control connections / contact	> 6 mm
Test voltage contact / contact contact / magnet system	2000 V 4000 V
Nominal switching capacity AC 250 V, 400 V	16 A, 10 A / 10 A, 6 A
Incandescent lamps and halogen lamp load 230 V	10 A (2300 W)
Fluorescent lamp load in DUO switching	16 A (3500 W) / 10 A (2000 W)
Fluorescent lamp load inductive or capacitive	10 A (1300 W)
Electronic ballasts	$I_{on} 140 A 10 ms / 70 A 10 ms$ ¹⁾
Fluorescent lamp load compensated in parallel	4 A (500 W)
Inductive load $\cos \varphi = 0.6 / 230 V AC$	10 A (1300 W)
High-pressure mercury lamp and metal halide lamp, uncompensated	500 W
Contact load DC max.	100 W
Mechanical endurance, change of position $10^3 / h$	> 10^6
Endurance with rated load, $\cos \varphi = 1$ und $10^3 / h$	> 10^5
Endurance with incandescent lamps 1000 W and $10^3 / h$	> 10^5
Endurance with rated load, $\cos \varphi = 0.6$ and $10^3 / h$	> 4×10^4
Switching frequency max.	$10^3 / h$
Switch position display	per contact
Manual operation	yes
Switch-on duration	100% ²⁾
Temperature at the installation location max. / min.	+50° / -5°C
Control voltage range	0.9 to 1.1 x U _n
Coil power loss AC + DC ± 20%	1- and 2-pole 5 - 6 W
Total power loss when continually excited	1-pole 7 - 8 W
Rated voltage and rated contact load	2-pole 9 - 10 W
Max. parallel capacity (length) of the control line	0.06 µF (200 m)
Max. induction voltage at the control inputs	0.2 x U _n
Glow lamps parallel to the 230 V control buttons	5 mA
With capacitor 1 µF / 250 V AC parallel to the coil	10 mA
With capacitor 2.2 µF / 250 V AC parallel to the coil	15 mA

1) For electronic ballasts, a switch-on current 40 times more powerful is to be expected.

2) If several remote switches and installation relays are under continuous excitation, please make sure that there is sufficient ventilation in accordance with the power

Function description:
FS = Remote switch

Type key
e.g. remote switch
article no. FS23011

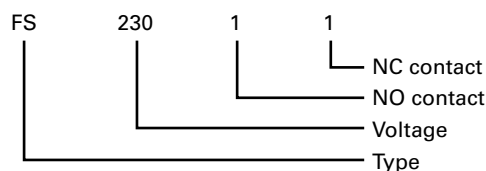

DIN-RAIL PANEL PRODUCTS

Remote switch central electronic control



REMOTE SWITCH CENTRAL CONTROL

16 A / 250 V
2 NO floating
Incandescent lamp load 2,000 W

1 M

	ARTICLE NO.	WEIGHT g/EACH	PACKING UNIT
8 to 230 V UC	FZU20	70	12

8 to 230 V UC	FZU20	70	12
---------------	-------	----	----

FZU20 – Local Universal Control Voltage 8...230V UC

With additional control inputs, central on and central off for 8...230V UC, with galvanic separation from the local control input.

Very low switching noise. Glow lamp current from 110 V control voltage up to 50 mA in switch positions 1 to 3 and 5 to 7.

A rotary switch allows for setting various priorities.

These determine which other control inputs are blocked as long as a control input is continually excited.

This will then determine how the remote switch reacts during failure and subsequent return of mains voltage:

In switch positions 1 to 4 the switching position remains unaltered.

Switch off is done in switch positions 5 to 8.

Central commands pending will then be executed.

OFF = Permanently OFF

Positions 1 + 5 = No priority. Local button pressing is even possible with permanently excited central control inputs. The final central command is carried out.

Positions 2 + 6 = Priority for central ON and OFF. Local button pressing is without any effect for the duration central OFF, however, has priority over central ON

Positions 3 + 7 = Priority for central ON and OFF. Local button pressing is without any effect for the duration central ON, however, has priority over central OFF.

Positions 4 + 8 = Priority for the permanently excited local button. Central commands are not carried out for the duration. Glow lamp current is not permitted in these positions.

ON = Continuously ON

Switching example of electronic impulse switch for central control

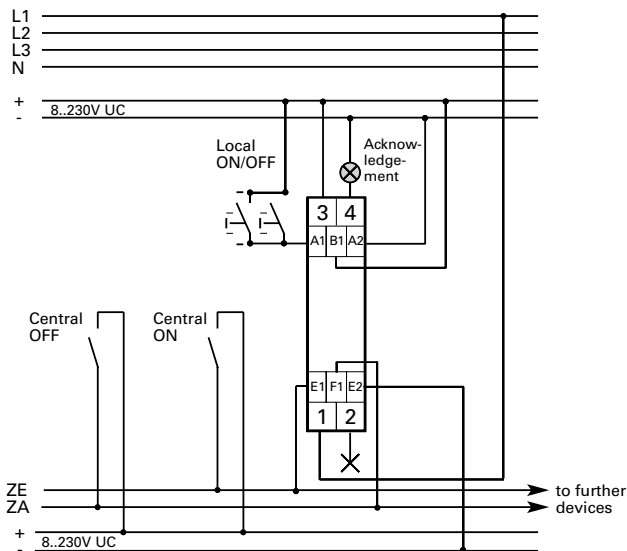

FZU20

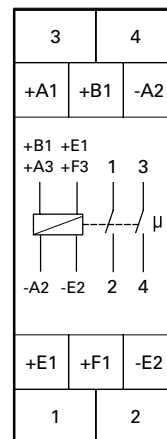

Function rotary switch

~~ZE-ZA~~ = no central control

ZA = only central control OFF

ZE = only central control ON + response delay 0, 1, 2 or 3 seconds

ZE ZA = central control ON and OFF + response delay 0, 1, 2 or 3 seconds

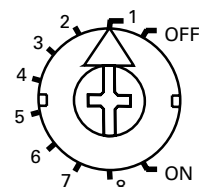

DIN-RAIL PANEL PRODUCTS

Electronic remote switch

Electronic remote switch	
Technical data / type	FZU20
Contacts	
Contact material / Contact interval	AgSnO ₂ / 0.5 mm
Interval control connections / contact	6 mm
Test voltage C1-C2 or A1-A2 / contact	4000 V
Test voltage contact / contact	4000 V
Test voltage control connections / contact	4000 V
Nominal switching capacity AC	16 A / 250 V
Incandescent lamps and halogen lamp load 230 V ¹⁾	2000 W
Fluorescent lamp load in (conventional ballast) DUO switching	1000 VA
Fluorescent lamp load in (conventional ballast) uncompensated or serially compensated	500 VA
Compact fluorescent lamps with electronic ballast and energy-saving lamps (ESL)	I_{ON} max. 70 A / 10 ms ²⁾
Max. switching current DC1: 12 V / 24 V DC	8 A
Endurance with rated load, $\cos \varphi = 1$ and incandescent lamps 1,000 W for 100 / h	$>10^5$
Endurance with rated load, $\cos \varphi = 0.6$ at 100 / h	$>4 \times 10^4$
Switching frequency max.	10^3 / h
Maximum cross section of a conductor (3-fold terminal)	6 mm ² (4 mm ²)
2 conductors with same cross-section (3-fold terminal)	2.5 mm ² (1.5 mm ²)
Screw head	Slotted / cross slot pozidriv
Protection cover (device side)	DIN EN 50274, VDE 00660-514 BGV A3

Electronics	
Switch-on duration (also for central ON/OFF)	100%
Temperature at the installation location max. / min.	+50 °C / -20 °C
Stand-by loss (active power) 230 V	0,4 W
Stand-by loss (active power) 12 V / 24 V	0.03 W / 0,06 W
Control current Universal control voltage all control voltages (< 5 s) \pm 20%	
Control current Universal control voltage 8/12/24/230 V (<10 s) \pm 20%	0.1 / 0.1 / 0.2 / 1 / (30) mA
Control current Central 8/12/24/230 V (<10 s) \pm 20%	2 / 4 / 9 / 5 / (100) mA
Max. parallel capacitance (length) of the central control line for 230 V AC	0.3 μ F (1000 m)
Max. parallel capacitance (length) of the central control line for 230 V AC	0.9 μ F (3000 m)

Fulfilled EN 50081-1, EN 50082-2 and EN 60669 standards

Bistable relay as NOC. Wait for short automatic synchronisation after installation before applying the switched load to the mains.

1) For lamps with max. 150 W

2) For electronic ballasts, a switch-on current 40 times more powerful is to be expected

DIN-RAIL PANEL PRODUCTS

Touch dimmer



TOUCH DIMMER

Universal control voltage
8 to 230 V UC,
R, L and C loads 400 W
Dimmable ESL 100 W
Dimmable LED, 230 V 100 W

1 M

ARTICLE NO.	WEIGHT g/EACH	PACKING UNIT
TDU500	96	1

Electronic universal touch dimmer for R, L and C loads

Universal control voltage 8..230 V UC, galvanically separated from supply and switching voltage 230 V.
Short control commands switch on/off, permanent activation adjusts brightness up to the maximum value.
A brief interruption of the activation alters the dimming direction.
The set level of brightness remains saved when switched off.

With switches for children's rooms:

When switching on and pressing the button for at least 1 second, the light will switch on at the lowest brightness level and slowly increase brightness, without altering the last brightness level saved.

With sleep function:

The lighting is dimmed from its current brightness and switches off when it receives a double impulse. The maximum dimming time of 60 minutes is dependent on the current brightness and can be shortened accordingly.
Switching-off during the dimming procedure is always possible by pressing the button briefly. Pressing the button for a longer time during the dimming procedure turns up the light and ends the sleep function.

Defined switch-off during electricity failure.

From 110 V control voltage, glow lamp current 30 mA
With the % -rotary switch the minimum brightness can be set (completely dimmed) e.g. for dimmable energy-saving lamps.

The **dim speed rotary switch** can be used to set the dimming speed. At the same time the duration of the soft ON and soft OFF is altered. The **+ESL** settings take into consideration the special conditions for dimmable energy-saving lamps: The switching-on procedure is optimised and the dimming rate is altered logarithmically. The children's room switch is not possible in these settings and wound (inductive) transformers are not allowed to be dimmed.

Memory is switched off in the **-ESL** setting. This can be advantageous with ESL, since cold ESL require a higher minimum brightness than might be stored in the memory with warm ESL.

The **LED** settings take into account the special conditions for dimmable 230V LED lamps. Different dimming curves can be selected. In these settings, no wound (inductive) transformers may be dimmed.

Automatic electronic overload protection and thermal overload switch-off.

L loads (inductive loads, e.g. wound transformers) and C loads (capacitor loads, e.g. electronic transformers) must not be mixed.
L and C loads can be mixed as desired with R loads (ohmic loads, e.g. 230 V incandescent and halogen lamps).

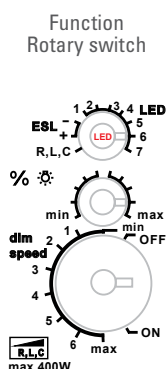

Technical data for dimmer TDU500 ¹⁾	
Incandescent lamps 230 V (R)	400 W
Halogen lamps 230 V (R)	400 W
Inductive transformers (L)	400 W ^{2) 3)}
Electronic transformers (C)	400 W ^{2) 3)}
Dimmable energy-saving lamps ESL	100 W ⁴⁾
Dimmable LED 230 V	100 W
Temperature at the installation location max. / min.	+50 °C / -20 °C ⁵⁾
Control voltage area	0.9 bis 1.1 x U _n
Constant current supply	12 mA

The parallel operation of inductive (wound) and capacitive (electronic) transformers is not allowed!

- For loads greater than 300 W, a ventilation interval of 1/2 module is to be maintained to devices mounted next to each other.
- A maximum of two inductive (wound) transformers are allowed per universal dimmer switch and only the same types may be used; in addition, secondary-side idling is not allowed. Otherwise the universal dimmer switch may be destroyed!
Therefore no secondary-side load switch-off allowed.
- When calculating loads, 20% loss for inductive (wound) transformers and 5% loss for capacitive (electronic) transformers must be taken into account in addition to the lamp load.
- In the ESL settings, no inductive (wound) transformers may be dimmed.
- Influences the maximum switching capacity.

Connection example

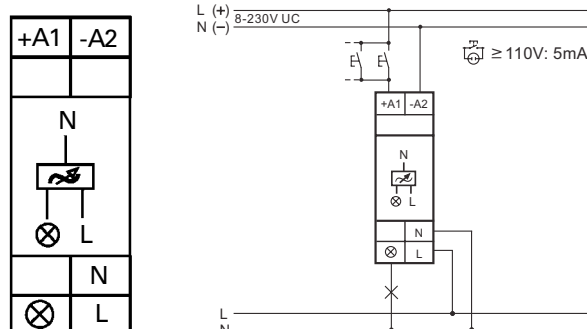

DIN-RAIL PANEL PRODUCTS

Load shedding relays



LOAD SHEDDING RELAYS

sealable
for electronically and pneumatically
regulated flow heaters

1 M

	ARTICLE NO.	WEIGHT g / EACH	PACKING UNIT
6,7-39 A	LRU39	90	12

6,7-39 A	LRU39	90	12
----------	-------	----	----

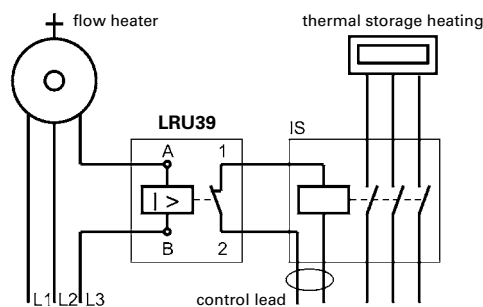

Load shedding relays			
Technical data / type	LRU39 for electronic and pneumatic flow heaters		
Field coil			
Rated current area AC	6.7 ... 39 A	Response current AC	< 5.3 A
Rated power for 230 V AC	1.5 ... 9 KW / 230 V~	Max. continuous current AC	43 A
Rated power for 230 / 400 V AC	4.6 ... 27 KW / 400 V~	Constant thermal load capacity 40°C	2.5 W
Operating / rated power	0.5 ... 4 VA	Connection terminal single wire	2.5 mm ² – 16 mm ²
		Connection terminal multiple wire	2.5 mm ² – 16 mm ²
Relay contact			
Contact	1 NC	Max. electrical switching frequency / h	approx. 1,800 switching cycles / h
Rated contact current for 250 V AC	1 A	Max. ambient temperature	40°C
Contact material	Hard silver gold-flashed	Response time / release time	10... 20 ms / 20 ... 30 ms
Max. switching voltage AC	400 V	Volume resistance	approx. 3 mΩ
Max. switching capacity	250 VA	Test voltage contact / coil AC	2.5 KV
Max. switch-on peak current	5 A	Isolation group acc. to VDE 0110	C / 250 V
Electric endurance with rated load	>100,000 switching cycles	Protection type housing	IP40
Mechanical endurance	approx. 1 million switching cycles	Connection terminal single wire	0.75 mm ² – 4 mm ²
Switch-on duration	100%	Connection terminal multiple wire	0.75 mm ² – 4 mm ²

DIN-RAIL PANEL PRODUCTS

Twilight switch



TWILIGHT SWITCH WITH SEPARATE LIGHT COLLECTOR

230 V~, 50 ... 60 Hz
16 A, 1 CO contact

2 M

ARTICLE NO.	WEIGHT g/ EACH	PACKING UNIT
DS2301W	230	1

DS2301W	230	1
---------	-----	---

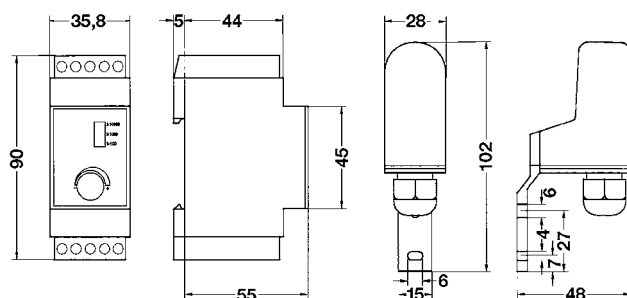

Twilight switch DS2301W	
Technical data	
Light intensity	Area 1 Area 2 Area 3
	2 -100 Lux 2 -1000 Lux 2 -10 000 Lux
Delay when switching on	8 sec.
Delay when switching off	38 sec.
Contact material	AgCdO
Contact interval	< 3 mm
Interval control connections / contact	5 mm
Rated insulation voltage contact / contact contact / magnet system	1 KV 4 KV
Switching capacity AC	16 A / 250 V $\cos \varphi = 1$
Incandescent lamp load	2300 W
Inductive load $\cos \varphi = 0.8$	3 A / 250 V
Mechanical endurance, change of position	5×10^7
Endurance with rated load, $\cos \varphi = 1$ and 10^3 / h	10^5
Endurance with incandescent lamps 1000 W and 10^3 / h	25×10^3
Endurance with rated load, $\cos \varphi = 0.6$ und 10^3 / h	75×10^3
Switch position display relay	LED red
Switch position display switch point	LED green
Switch-on duration	100%
Temperature at the installation location min. / max.	0°C to 55°C
Total power loss during continuous excitation	2.2 W
Degree of protection	IP20
Protection type light collector	IP65
Max. cable length to light collector	100 m

Wiring diagram:
Twilight switch
with separate light collector

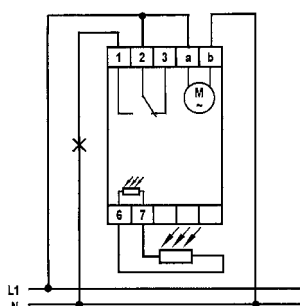

DIN-RAIL PANEL PRODUCTS

Time relays and multi-function time relays



MULTI-FUNCTION TIME RELAYS

16 functions
1 CO contact 10 A / 250 V~
Time range 0.1 sec. - 40 hrs

1 M

	ARTICLE NO.	WEIGHT g / EACH	PACKING UNIT
8 V to 230V UC	MRU1W	75	10

8 V to 230V UC	MRU1W	75	10
----------------	-------	----	----



TIME RELAYS

1 CO contact 10 A / 250 V~
Time range 0.1 sec. - 40 hrs

1 M

	ARTICLE NO.	WEIGHT g / EACH	PACKING UNIT
8 V to 230V UC	RVU1W	75	1

8 V to 230V UC	RVU1W	75	1
----------------	-------	----	---

Function description MRU1W

Stand-by loss only 0.1 Watt

Depending on the connection for the electricity supply to terminal B1 or B2, **two different function levels can be selected:**

Function level 1 for connection of electricity supply to B1-A2

- RV** = Release delay
- AV** = Response delay
- TI** = Clock generator starting with impulse
- TP** = Clock generator starting with pause
- IA** = Impulse-controlled response delay
- EW** = Passing make contact

- AW** = Passing break contact
- ARV** = Response and release delay
- ON** = Continuously ON
- OFF** = Permanently OFF

Function level 2 for connection to electricity supply to B2-A2

- ER** = Relay function
- EAW** = Passing make and break contact
- Er S** = Impulse switch function
- IF** = Impulse former
- ARV+** = Additive response and release delay
- ESV** = Impulse switch with release delay and Pre-warning of switch-off
- AV+** = Additive response delay
- SRV** = Impulse switch with release delay
- ON** = Continuously ON
- OFF** = Permanently OFF

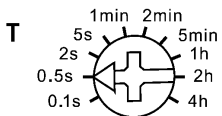
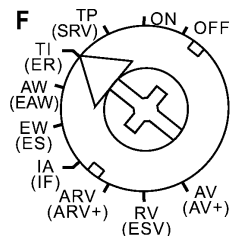

The time base T

is set for latching rotary switches [T]. There is a choice between the base values 0.1 seconds, 0.5 seconds, 2 seconds, 5 seconds, 1 minute, 2 minutes, 5 minutes, 1 hour, 2 hours and 4 hours. The total time is calculated from the time base multiplied by the multiplier.

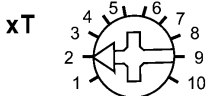

The multiplier x T

is set with the latching rotary switch [xT] and is between 1 and 10. This makes it possible to set times between 0.1 seconds (time base 0.1 seconds and multiplier 1) and 40 hours (time base 4 hours and multiplier 10).

Light emitting diode

under the large rotary switch provides information about the contact position during the time period. It blinks as long as NOC 15 -18 is open (15 -16 closed) and glows continuously as long as NOC 15 -18 is closed (15-16 open).

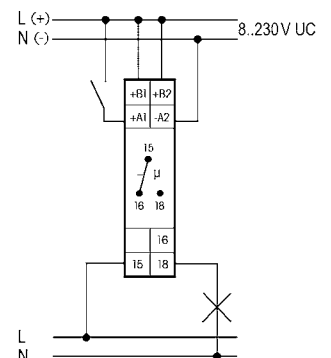
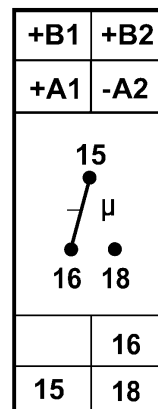

DIN-RAIL PANEL PRODUCTS

Time relays and multi-function time relays · Function descriptions

RV = Release delay (Delay in switching off)

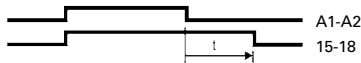

When applying control voltage, the NOC changes to 15–18. With the interruption of the control voltage, the time period begins and at its end the NOC returns to its rest position. Can be reset during the time period.

AW = Passing break contact relay

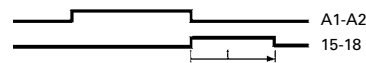

When the control voltage is interrupted, the NOC changes to 15–18 and returns after the impulse time has elapsed. If the control voltage is applied during the impulse time, the NOC immediately reverts to its rest position and the residual time is deleted.

AV = Response delay (Delay when switching on)

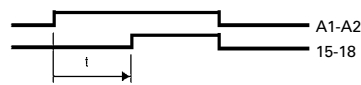

With the application of the control voltage, the time period begins and at its end the NOC changes to 15–18. After an interruption, the time period starts again.

ARV = Response and release delay

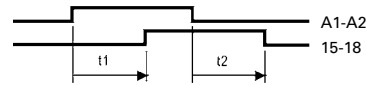

When the control voltage is applied, the timing period is started; at its end the NOC changes to 15–18. If the control voltage is interrupted after this, another timing period is started; at its end the NOC returns to the rest position. This release delay is identical to the response delay. After an interruption of the response delay, the time period begins again.

TI = Clock generator starting with impulse

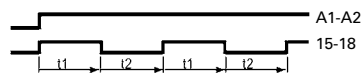

As long as the control voltage is applied, the NOC closes and opens. For MRU1W the switching time in both directions is identical and corresponds to the time set. For TIUMW both times can be set separately. When the control voltage is applied, the NOC immediately changes to 15–18.

EAW = Passing make contact relay and passing break contact relay

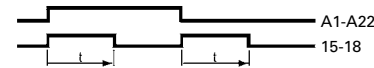

When the control voltage is applied and interrupted, the NOC changes to 15–18 and returns after the set impulse time has elapsed.

TP = Clock generator starting with pause (Flashing relay)

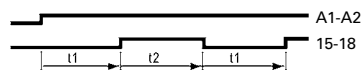

Function descriptions same as TI, except that when the control voltage is applied, the contact does not change to 15–18 but rather first remains at 15-16 or open.

IF = Impulse former

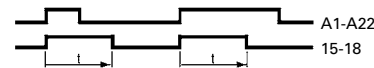

When the control voltage is applied, the NOC changes to 15–18 for the time set. Further activations are only evaluated after the set time has elapsed.

IA = Impulse-controlled response delay

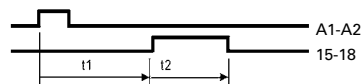

With the start of a control pulse from 20 ms, the timing period t_1 starts; at its end, the NOC changes to 15–18 for the time t_2 (=1 second) (e.g. for automatic door openers). If t_1 is set to the shortest time of 0.1 seconds, IA operates as an impulse former, for which t_2 elapses, independent of the control signal's duration (min. 150ms).

ARV+ = Additive response and release delay

Same function as the ARV, but after an interruption of the response delay, the elapsed time remains stored.

ESV = Impulse switch with release delay and pre-warning of switch-off

Function as SRV. Also with pre-warning of switch-off: approx. 30 sec. before time elapses, the light flickers 3 times in shorter and shorter periods.

EW = Passing make contact relay

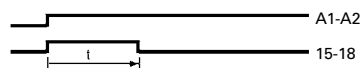

With the application of the control voltage, the NOC changes to 15–18 and returns after the impulse time. If the control voltage is removed during the impulse time, the NOC immediately returns to the rest position and the remaining time is deleted.

AV+ = Additive response delay

Same function as the AV, but after an interruption, the time already elapsed remains stored.

SRV = Impulse switch with release delay

The NOC switches back and forth with control impulses from 50 ms. In contact position 15-18, the device automatically switches to the rest position after the delay time has elapsed.

DIN-RAIL PANEL PRODUCTS

Time relays and multi-function relays

Time relays and multi-function relays	
Technical data / type	MRU1W / AVU1W / RVU1W
Switch-on duration	100%
Temperature at the installation location max. / min.	+50 °C / -20 °C
Contact material / contact interval	AgSnO ₂ / 0.5 mm
Interval control connections / contact	3 mm
Test voltage contact / contact	1000 V
Test voltage control connections / contact	2000 V
Nominal switching capacity AC	10 A / 250 V
Incandescent lamps and fluorescent lamps, inductive or capacitive	1000 W
Fluorescent lamps in DUO switching	1000 W
Fluorescent lamps compensated in parallel	500 W
Electronic ballasts	$I_{ON} \max 70 \text{ A} / 10 \text{ ms}^{2)}$
Inductive load $\cos \varphi = 0.6 / 230 \text{ V AC}$	650 W
Max. switching current DC 1 (not for NP type): 12 V / 24 V DC	8 A
Endurance with rated load, $\cos \varphi = 1$ and incandescent lamps 1000 W for 100 / h	$>10^5$
Endurance with rated load, $\cos \varphi = 0.6$ bei 100 / h	$>4 \times 10^4$
Temperature dependency	$<0,2\%$ each °C
Repetition accuracy at 25 °C	$\pm 0,1\%$
Setting accuracy from 1 minute	$\pm 0,2\%$
Control voltage dependency between 0.8 and 1.1 x U _n	none
Bridging time during mains failures (then total reset)	min. 0.2 seconds
Control current 12 V / 230 V $\pm 20\%$	0.05 / 0.9 mA
Control current 12 V DC / 230 V DC $\pm 20\%$	0.09 / 1.7 mA
Power consumption continuous electricity supply 12 V / 230 V UC relay OFF	0.02 / 0.4 W
Power consumption continuous electricity supply 12 V / 230 V UC relay ON	0.3 / 1.0 W ³⁾
Max. parallel capacity (length) of the control lines for 230 V	0.2 μF (approx. 600 m)
Protection cover (device side)	DIN EN 50274, VDE 0660-514 BGV A3
Box terminal cross section	12 mm ²
Maximum cross section of a conductor	6 mm ²
Screw head	Slotted / cross slot pozidriv

Meets VDE0435, EN 61000-6-3, EN 61000-6-1 and EN 60669 standards

1) Only with constant mains voltage $>110 \text{ V}$ and only when "relay on" for more than 60 minutes, is it necessary to maintain a ventilation interval of 1/2 module on both sides. If required, use the distance device.
For 230 V AC, a capacitor 0.33 μF / 250 V in series with B1 is also sufficient.

2) For electronic ballasts, a switch-on current 40 times more powerful is to be expected.

DIN-RAIL PANEL PRODUCTS

Mains monitoring



MAINS MONITORING
NW1
NWA1 asymmetrical monitoring
UAB 154 V, UAN 198 V

2 M

	ARTICLE NO.	WEIGHT g / EACH	PACKING UNIT
--	-------------	-----------------	--------------

1NO + 1NC	NW1	98	1
	NWA1	98	1

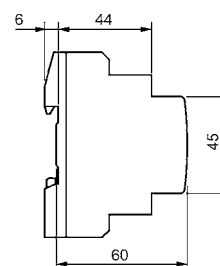
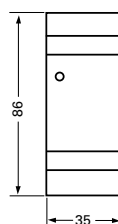

MAINS MONITORING
NW2
NWA2 asymmetrical monitoring
UAB 187 V, UAN 210 V

2 M

	ARTICLE NO.	WEIGHT g / EACH	PACKING UNIT
--	-------------	-----------------	--------------

1S + 1Ö	NW2	98	1
	NWA2	98	1

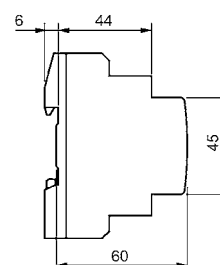
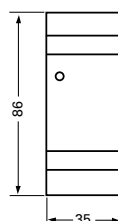

Mains monitoring		NW1 / NW2	NWA1 / NWA2
Technical data / type			
Mains connection		1 - 3-phase 230 / 400 V	3-phase 230 / 400 V
Operational voltage		via L1-N 230 V AC	
Frequency		45...65 Hz	
Power consumption		5.5 VA	
Response / drop delay		0.15...0.5 sec.	
Input pulse amplitude max. 6 ms 20 ms		2.5 KV 1.0 KV	
Asymmetrical monitoring		none	10%
Back-up fuse		no / device inherently stable	
Relays			
Contact material		Ag Ni 0.15 + HV	
Contact interval		> 0.35	
Interval control connections / contact		15 mm	
Rated insulation voltage contact / contact contact / magnet system		1000 V _{eff} 4000 V _{eff}	
Rated switching capacity		2000 VA	
Contact load DC max. (A) 24 V		8 A	
60 V		1.8 A	
110 V		0.4 A	
220 V		0.3 A	
Minimum contact load		10 mA / 12 V	
Mechanical endurance		3 x 10 ⁷	
Endurance with rated load, cos φ =1		100 000	
Endurance with rated load cos φ = 0.4		80 000	
Switching frequency max.		3000 / h	
Switch position display		LED	
Switch-on duration / switching safety		100%	
Temperature at the installation location max. / min.		-40°C / + 70°C	
Total power loss during constant excitation		0.55 VA	

DIN-RAIL PANEL PRODUCTS

Installation contactors



INSTALLATION CONTACTOR
20 A / 230 V AC
2-pole · Control voltage 230 V AC

1 M

	ARTICLE NO.	WEIGHT g/EACH	PACKING UNIT
2NO	IS2020	200	12
1NO 1NC	IS2011	200	12

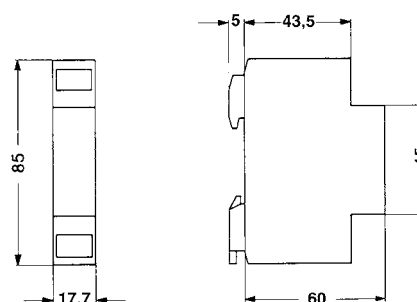

INSTALLATION CONTACTOR
25 A 230 / 400 V AC
4-pole · Control voltage 230 V AC

2 M

	ARTICLE NO.	WEIGHT g/EACH	PACKING UNIT
4NO	IS2540	280	6
2NO 2NC	IS2522	280	6
3NO 1NC	IS2531	280	6

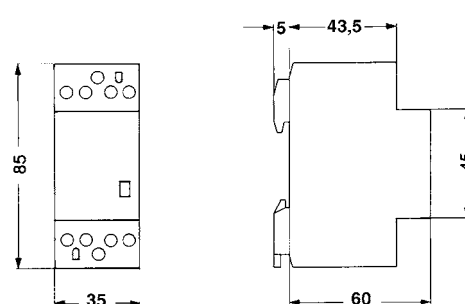

INSTALLATION CONTACTOR
40 A and 63 A 230 / 400 V AC
4-pole · Control voltage 230 V AC

3 M

	ARTICLE NO.	WEIGHT g/EACH	PACKING UNIT
4NO	IS4040	450	4
4NO	IS6340	450	4

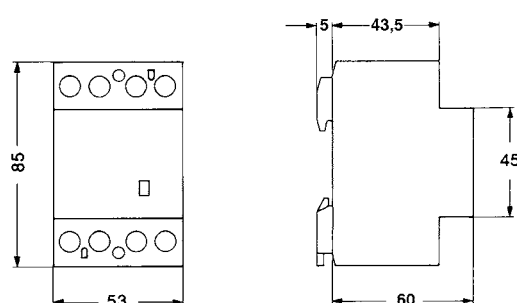

AUXILIARY CONTACT
Continuous thermal current $I_{th} = 6$ A
Rated operating current I_e
with AC - 15 for U_e 240 V AC 3 A
415 V AC 2 A
440 V AC 1,6 A

½ M

	ARTICLE NO.	WEIGHT g/EACH	PACKING UNIT
1NO 1NC	ISH11	23	3

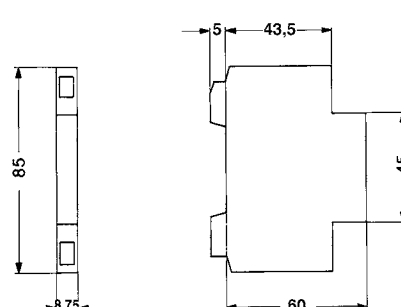

SEALING CAP

	ARTICLE NO.	WEIGHT g/EACH	PACKING UNIT
2 M	ISP2	2	10
3 M	ISP3	3	10



DISTANCE DEVICE 9MM

	ARTICLE NO.	WEIGHT g/EACH	PACKING UNIT
½ M	ISD	13	10

We recommend the use of distance devices at ambient temperatures higher than 40° C

DIN-RAIL PANEL PRODUCTS

Installation contactors

Technical data acc. to IEC 60947-3, IEC 60947-5-1, VDE 0660, EN 60947-3, EN 60947-5-1

Main contact element types		IS20..	IS25..	IS40..	IS63..
Rated insulation voltage U_i	V AC	440	440	440	440
Rated operating voltage U_e	V AC	440	440	440	440
Allowed switching frequency z	AC1, AC3 1 / h	300	300	600	600
Mechanical endurance	S x 10 ⁶	1	1	1	1

Usage category AC1

Rated operating current I_e (= I_{th}) open	at 60 °C A	20	25	40	63
Switching element endurance	S x 10 ⁶	0.1	0.1	0.1	0.1
Power loss per pole for I_e / AC1	W	2	2	3	7

Usage category AC3 – Switching of three-phase motors

Rated operating current I_e	A	-	9	27	30
Rated power for 220 V	kW	-	2.2	7.5	8
Three-phase motors 50 - 60Hz	230 - 240 V	kW	2.5	8	8.5
	380 - 415 V	kW	4	12.5	15
Switching element endurance	S x 10 ⁶	-	0.15	0.15	0.15

Magnetic coil

Magnetic coil output	Switching VA	7 - 9	14 - 18	33 - 45	33 - 45
	Stop VA	2.2 - 4.2	4.4 - 8.4	7	7
Alternating current activation	W	0.8 - 1.6	1.6 - 3.2	2.6	2.6

Magnetic coil operating areas

Control voltage dependency U_s		0.85 - 1.1	0.85 - 1.1	0.85 - 1.1	0.85 - 1.1
----------------------------------	--	------------	------------	------------	------------

Short circuit protection

Max. back-up fuse main circuits	gL (gG) / A	35	35	63	80
Switching times for control voltage $U_s \pm 10\%$	Closing delay ms	7 - 16	9 - 15	11 - 15	11 - 15
	Opening delay ms	6 - 12	4 - 8	6 - 13	6 - 13
	Arc duration ms	10 - 15	10 - 15	10 - 15	10 - 15

Connection cross sections

Single or multiple wire main conductor	mm ²	1.5 - 10	1.5 - 10	2.5 - 25	2.5 - 25
Stranded wire	mm ²	1.5 - 6	1.5 - 6	2.5 - 16	2.5 - 16
Stranded wire with ferrule	mm ²	1.5 - 6	1.5 - 6	2.5 - 16	2.5 - 16
Number of clampable conductors per terminal		1	1	1	1
Coil single wire or multiple wire	mm ²	0.75 - 2.5	0.75 - 2.5	0.75 - 2.5	0.75 - 2.5
Stranded wire	mm ²	0.5 - 2.5	0.5 - 2.5	0.5 - 2.5	0.5 - 2.5
Stranded wire with ferrule	mm ²	0.5 - 1.5	0.5 - 1.5	0.5 - 1.5	0.5 - 1.5
Number of clampable conductors per terminal		1	1	1	1

Auxiliary contact ISH11

Rated insulation voltage U_i	V AC	440			
Thermal rated current = I_{th}	40 °C	A	10		
	60 °C	A	6		

Usage category AC15

Rated operating current I_e	220 - 240 V	A	3		
	380 - 415 V	A	2		
	440 V	A	1.6		

Usage category DC13

Rated operating current I_e each pole	24 - 60 V	A	2		
	110 V	A	0.4		
	220 V	A	0.1		

Short-circuit protection

Largest rated current of the fuses short-circuit current 1kA, without welding the contacts	gL (gG) / A	10			
--	-------------	----	--	--	--

DIN-RAIL PANEL PRODUCTS

Installation contactor IS – Switching of lamp loads

LAMP TYPE	OUTPUT Watt	CURRENT I_n / A	CAPACITOR μ F	MAX. NUMBER OF LAMPS PER CONDUCTING PATH FOR 230 V 50 HZ AND MAX. 60 °C			
				IS20..	IS25..	IS40..	IS63..
Incandescent lamps	60	0,27	-	22	28	92	129
	100	0,45	-	13	17	55	77
	200	0,91	-	7	8	27	38
	300	1,36	-	4	5	19	26
	500	2,27	-	3	3	11	16
	1000	4,5	-	1	1	6	8
Fluorescent lamps Uncompensated or Serially compensated	11	0.16	1,3	60	75	210	310
	18	0.37	2,7	25	30	90	140
	24	0.35	2,5	25	30	90	140
	36	0.43	3,4	20	25	70	140
	58	0.67	5,3	14	17	45	70
	65	0.67	5,3	13	16	40	65
	85	0.8	5,3	11	14	35	60
Fluorescent lamps Duo switching	11	0.07	-	2 x 100	2 x 110	2 x 220	2 x 250
	18	0.11	-	2 x 50	2 x 55	2 x 130	2 x 200
	24	0.14	-	2 x 40	2 x 44	2 x 110	2 x 160
	36	0.22	-	2 x 30	2 x 33	2 x 70	2 x 100
	58	0.35	-	2 x 20	2 x 22	2 x 45	2 x 70
	65	0.35	-	2 x 15	2 x 16	2 x 40	2 x 60
	85	0.47	-	2 x 10	2 x 11	2 x 30	2 x 40
Fluorescent lamps Parallel compensation	11	0.09	2	30	43	67	107
	18	0.13	2	20	32	50	80
	24	0.16	3	15	32	50	80
	36	0.27	4	10	32	50	80
	58	0.45	7	6	18	36	46
	65	0.5	7	5	18	36	46
	85	0.6	8	4	18	33	44
Fluorescent lamps with electronic ballast	18	0.09	-	40	40	100	150
	36	0.16	-	20	20	50	75
	58	0.25	-	15	15	30	55
	2 x 18	0.17	-	2 x 20	2 x 20	2 x 50	2 x 60
	2 x 36	0.32	-	2 x 10	2 x 10	2 x 25	2 x 30
	2 x 58	0.49	-	2 x 7	2 x 7	2 x 15	2 x 20
Transformers for low-voltage halogen lamps	20	0.09	-	40	52	110	174
	50	0.22	-	20	24	50	80
	75	0.33	-	13	16	35	54
	100	0.43	-	10	12	27	43
	150	0.65	-	7	9	19	29
	200	0.87	-	5	5	14	23
	300	1.3	-	3	4	9	14
Mercury high-pressure lamps uncompensated e.g. high-pressure mercury lamp and metal halide lamp	50	0.61	-	16	21	38	55
	80	0.8	-	12	16	29	40
	125	1.15	-	8	11	20	28
	250	2.15	-	4	6	11	15
	400	3.25	-	3	4	7	10
	700	5.4	-	1	2	4	6
	1000	7.5	-	1	1	3	4
Mercury high-pressure lamps compensated e.g. high-pressure mercury lamp and metal halide lamp	50	0.28	7	7	18	36	50
	80	0.41	8	5	16	31	44
	125	0.65	10	3	13	25	35
	250	1.22	18	2	7	14	19
	400	1.95	25	1	5	10	14
	700	3.45	45	1	3	6	8
	1000	4.8	60	-	2	4	6

DIN-RAIL PANEL PRODUCTS

Installation contactor IS – Switching of lamp loads

LAMP TYPE	OUTPUT Watt	CURRENT I_n / A	CAPACITOR μ F	MAX. NUMBER OF LAMPS PER CONDUCTING PATH FOR 230 V 50 HZ AND MAX. 60 °C			
				IS20..	IS25..	IS40..	IS63..
Metal halogen lamps uncompensated e.g. high-pressure mercury lamp and metal halide lamp, CDM	35	0.53	-	22	24	57	65
	70	1	-	12	14	30	35
	150	1.8	-	6	8	17	18
	250	3	-	4	5	10	12
	400	3.5	-	3	4	8	10
	1 000	9.5	-	1	1	3	4
	2 000	16.5	-	-	-	2	2
	2 000 / 400 V	10.5	-	-	-	2	2
3 500 / 400 V	18	-	-	-	1	1	
Metal halogen lamps compensated e.g. high-pressure mercury lamp and metal halide lamp, CDM	35	0.25	6	8	21	42	58
	70	0.45	12	4	11	21	29
	150	0.75	20	2	7	13	18
	250	1.5	33	1	4	9	11
	400	2.1	35	1	4	9	10
	1 000	5.8	95	-	1	3	4
	2 000	11.5	148	-	-	2	2
	2 000 / 400 V	6.6	58	-	-	3	4
3 500 / 400 V	11.6	100	-	-	2	3	
Metal halogen lamps with electronic ballast (e.g. PCI) 50 - 125 x I_n lamps for 0.6 ms	20	0.1	Integrated	9	9	18	20
	35	0.2	Integrated	6	6	11	13
	70	0.36	Integrated	5	5	10	12
	150	0.7	Integrated	4	4	8	10
Low pressure sodium vapour lamps uncompensated	35	1.5	-	7	9	22	30
	55	1.5	-	7	9	22	30
	90	2.4	-	4	6	13	19
	135	3.3	-	3	4	10	14
	150	3.3	-	3	4	10	14
	180	3.3	-	3	4	10	14
	200	3.3	-	3	4	10	14
Low pressure sodium vapour lamps compensated	35	0.31	20	3	6	15	18
	55	0.42	20	2	6	15	18
	90	0.63	30	1	4	10	12
	135	0.94	45	1	3	7	8
	150	1	40	1	3	8	9
	180	1.16	40	1	3	8	9
	200	1.32	25	-	-	10	12
High pressure sodium vapour lamps uncompensated	150	1.8	-	5	8	17	22
	250	3	-	4	5	10	13
	330	3.7	-	3	4	8	10
	400	4.7	-	2	3	6	8
	1 000	10.3	-	1	1	3	4
High pressure sodium vapour lamps compensated	150	0.83	20	2	7	20	25
	250	1.5	33	1	4	12	15
	330	2	40	1	3	10	13
	400	2.4	48	1	2	8	12
	1 000	6.3	106	-	1	4	6
High pressure sodium vapour lamps Sodium vapour lamps with electronic ballast (e.g. PCI) 50 - 125 x I_n lamp for 0.6 ms	20	0.1	Integrated	9	9	18	20
	35	0.2	Integrated	6	6	11	13
	70	0.36	Integrated	5	5	10	12
	150	0.7	Integrated	4	4	8	10

DIN-RAIL PANEL PRODUCTS

Stairway light time switches



STAIRWAY LIGHT TIME SWITCHES WITH PRE-WARNING OF SWITCH-OFF

230 V AC 50 / 60 Hz
 16 A 1 NO (not floating)
 Time range 1 to 30 minutes
 Incandescent lamp load 2300 W
 Glow lamp current 50 mA

1 M

ARTICLE NO.	WEIGHT g/EACH	PACKING UNIT
TZA2301	76	12

TZA2301 Stairway light time switches Stand-by loss only 0.5 Watt.

Contact circuit in zero crossing to protect the contacts and lamps. This is especially good for increasing the endurance for energy-saving lamps. Very low switching noise.
 Exact time settings from 1 to 30 minutes with minute scale.
 Control, supply and switching voltage 230 V. Also with galvanically separated universal control voltage 8...230 V UC.
 Glow lamp current up to 50 mA, independent of the glow lamp ignition voltage.

Own continuous light switch with large rotary switch.

When the pre-warning switch-off is activated , the light flickers approx. 30 seconds before time elapses and 3 times in total in shorter and shorter periods.

When the continuous light button is activated, pressing the button for longer than one second can activate the continuous light, which is automatically switched off after 60 minutes or can be switched off by pressing for longer than 2 seconds.

If the continuous light button and the pre-warning of switch-off are activated, then the pre-warning of switch-off only activates after switching off the continuous light.

If energy-saving lamps are switched (ESL) completely or partly, then set the pre-warning of switch-off and the continuous light button on the right ESL side of the rotary switch.

Within 1 second after switch-on or subsequent switch-on, the **time** can be **extended** (pumped) with the TLZ functions by briefly pressing the button three times. Every touch adds one time to the set time.

Multifunctional: Can switch between the **FS** (impulse relay), **ST** (relay) and **ESV** (impulse relay with release delay) functions. The ESV function, the times (t) settable with the rotary switch above correspond to the following values: 1 = 2 min, 2 = 5 min, 3 = 10 min, 4 = 15 min, 6 = 25 min, 8 = 35 min, 10 = 45 min, 12 = 60 min, 20 = 90 min, 30 = 120 min.

After the set delay time has elapsed, automatic switch-off is carried out if the manual OFF command was not given. Pre-warning of switch-off and the continuous light button can be connected for ESV. Forgotten continuous light is switched off after 2 hours.

Connection examples

3-conductor circuit with subsequent switching

4-conductor circuit, with attic lighting, with subsequent switching

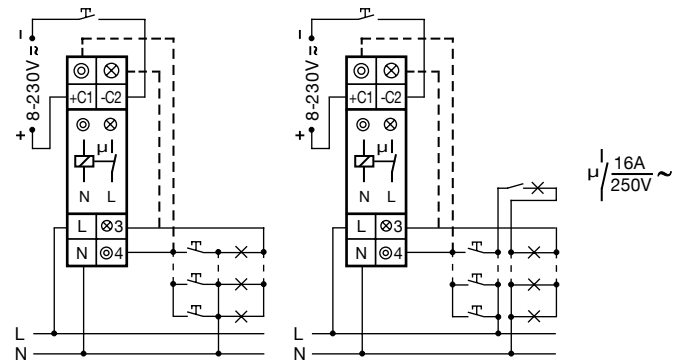

Automatic mode:

pre-warning switch

continuous light button

TLZ: $t_{max} = 30 \text{ min}$
 ESV: $t_{max} = 120 \text{ min}$

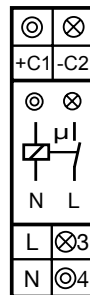

With double connections for button and lamp so that they can be connected above and below or only below.

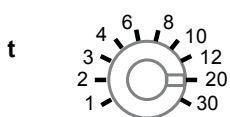

Time setting

TLZ / ESL t = time 1 to 30 minutes

ESV t = time 2 to 120 minutes

Function selection switch TLZ / ESV and ESL

= Pre-warning of switch-off

= Continuous light button

= Continuous light button + pre-warning of switch-off

= Continuous light switch

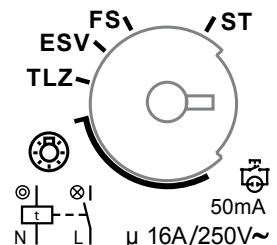
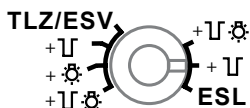

DIN-RAIL PANEL PRODUCTS

Stairway light time switches

Technical data stairway light time switch	TZA2301 *
Contacts	
Contact material / contact interval	AgSnO ₂ / 0.5mm
Interval control connections / contact	3 mm
Interval A1-A2 / contact	6 mm
Test voltage control connections / contact	2 000 V
Test voltage A1-A2 / contact	4 000 V
Nominal switching capacity AC	16 A / 250 V
Incandescent lamps and halogen lamp load 230 V ¹⁾	2 300 W
Fluorescent lamp load (conventional ballast) In DUO switching or uncompensated	1 000 VA
Fluorescent lamp load (conventional ballast) with parallel compensation or with electronic ballast	500 VA
Compact fluorescent lamps with electronic ballast And energy-saving lamps ESL	15 x 7 W 10 x 20 W
Endurance with rated load, $\cos \varphi = 1$ or for incandescent lamps 1000 W for 100 / h	>10 ⁵
Endurance with rated load, $\cos \varphi = 0.6$ to 100 / h	>4 x 10 ⁴
Switching frequency max.	10 ³ / h
Box terminal cross sections	12 mm ²
Maximum cross section of a conductor	6 mm ²
Screw head	Slotted / cross slot, pozidriv slot
Protection cover (device side)	VDE 0106 part 100

Electronics	
Switch-on duration	100%
Temperature at the installation location max. / min.	+50 °C / -20 °C
Stand-by loss (active power)	0.5 W
Control current locally at 230 V (<10 s) ± 20%	5 (100) mA
Max. parallel capacity (approx. length) of the individual control lines for 230 V AC	0.06 µF (approx. 200 m)

Fulfilled EN 61000-6-3, EN 61000-6-1 and EN 60 669 standards

With pre-warning of switch-off acc. to DIN 18015-2

* Bistable relay as NOC. Wait for automatic synchronisation after installation before applying the switched load to the mains.

1) For lamps with max. 150 W.

DIN-RAIL PANEL PRODUCTS

Synchronised / Quartz time switch



SYNCHRONISED TIME SWITCH

230 V~ 50 Hz
16 A, 1 CO contact
without power reserve

3 M

	ARTICLE NO.	WEIGHT g/EACH	PACKING UNIT
24 h	AZ1TS	200	1
7 Tage	AZ7TS	200	1

24 h	AZ1TS	200	1
7 Tage	AZ7TS	200	1

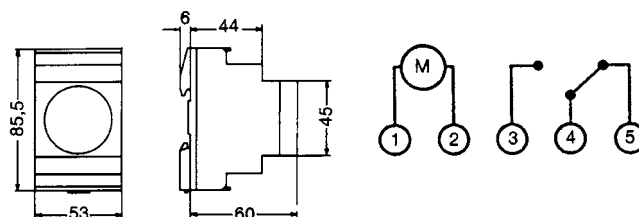

QUARTZ TIME SWITCH

230 V~ 50 / 60 Hz
16 A, 1 CO contact
Power reserve 150 h

3 M

	ARTICLE NO.	WEIGHT g/EACH	PACKING UNIT
24 h	AZ1TQ	200	1
7 Tage	AZ7TQ	200	1

24 h	AZ1TQ	200	1
7 Tage	AZ7TQ	200	1

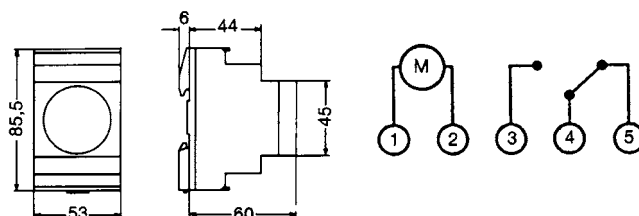

Technical data / type	AZ1TS / AZ7TS	AZ1TQ / AZ7TQ
Operating voltage	220 - 240 V AC	230 V AC / 130 V DC
Frequency	50 Hz	45 - 60 Hz
Power consumption	approx. 1 VA	
Power reserve	-	150 h battery
Charge time	-	70 h
Accuracy	Network synchronisation	± 2.5 sec. / day at 20 °C
Minimum switch-on duration	30 min 3 h	
Programming	30 min 3 h	
Manual switch	Continuous OFF / clock operations / continuously ON	
Contacts	1 CO contact	
Contact power	16 A / 250 V AC μ 4 A / 250 V AC	
For incandescent lamps	1350 W	
Temperature range	-25 °C to +55 °C	
Protection class	II acc. to EN 60335-1	
Degree of protection	IP20 acc. to EN 60529	

DIN-RAIL PANEL PRODUCTS

Digital timer



DIGITAL TIMER

230 V~, 50/60 Hz, 16 A
 1 channel, 50 storage places
 2 channels, 50 storage places
 Program 24 h, 7 days

2 M

	ARTICLE NO.	WEIGHT g / EACH	PACKING UNIT
1 channel	DZ201	170	1
2 channels	DZ302	170	1

1 channel	DZ201	170	1
2 channels	DZ302	170	1

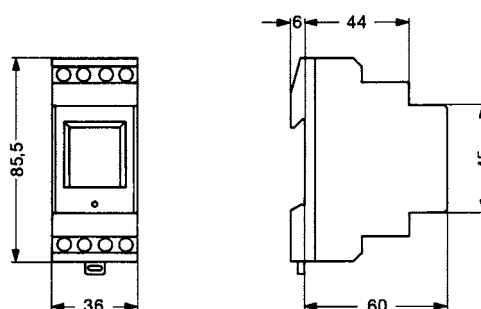

Technical data / Typ	DZ201	DZ302
Operating voltage	220-240 V / 50-60 Hz	
Power input up to 230 V~ (AC)	5 VA	
Switching capacity AC Ohmic load (VDE, IEC) Inductive load cos. φ 0,6 Incandescent lamp load	16 A / 250 V AC 8 A / 250 V AC 1000 W	
Switching capacity DC 24 V– 50 V– 220 V–	800 mA 300 mA 150 mA	
Switching output	Floating	
Switching contacts	1 CO contact	2 CO contact
Ambient temperature	–25 °C *) ... + 55 °C	
Protection class	II acc. to EN 60335-1	
Accuracy	type \pm 1 s / day when +20 °C	
Power reserve	3 years ex works for +20 °C	
Shortest switching time	1 min	
Programmable	1 min	
Storage places	50	
Manual switch	Automatic / pre-selection Fix ON/ Fix OFF	
Block formation of week days	Free assignment	
Display switch state	Yes	
Daylight saving time option	automatic / free selection / off	
Max. conductor cross section	4 mm ²	
Type of connection	Captive \pm screw terminals	
Sealable	Yes	
Programming	Menu in 15 languages	

*) for limited display functions

DIN-RAIL PANEL PRODUCTS

Transformers



SAFETY BELL TRANSFORMER
 230 V~ 50 Hz
 U/I secondary
 8 - 12 V / 1 – 0.67 A
 Short-circuit proof with PTC

2 M

	ARTICLE NO.	WEIGHT g/EACH	PACKING UNIT
8 VA	KT08	211	1

8 VA	KT08	211	1
------	-------------	-----	---

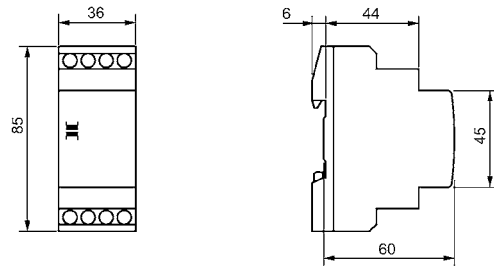

SAFETY BELL TRANSFORMER
 230 V~ 50 Hz
 U/I secondary
 16 VA 8-12-24 V / 1.3-1.3-0.67 A
 24 VA 8-12-24 V / 2-2-1 A
 Short-circuit proof with PTC

3 M

	ARTICLE NO.	WEIGHT g/EACH	PACKING UNIT
16 VA	KT16	537	1
24 VA	KT24	758	1

16 VA	KT16	537	1
24 VA	KT24	758	1

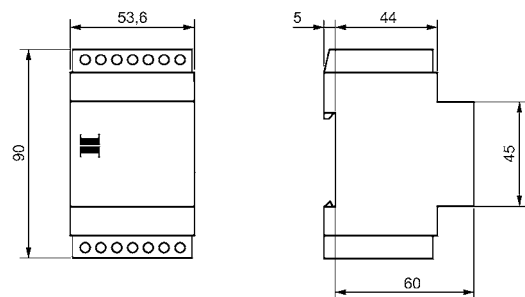

SAFETY TRANSFORMER
 230 V~ 50 Hz
 U/I secondary 12-12 V / 1.67-1.67 A
 Parallel circuit 12 V / 3.3 A
 Series circuit 24 V / 1.67 A
 Short-circuit proof with PTC

3 M

	ARTICLE NO.	WEIGHT g/EACH	PACKING UNIT
40 VA	ST40	790	1

40 VA	ST40	790	1
-------	-------------	-----	---

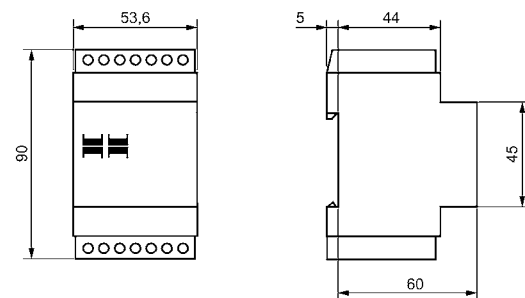

SAFETY TRANSFORMER
 230 V~ 50 Hz
 U/I secondary 12-12 V / 2.63-2.63 A
 Parallel circuit 12 V / 5.25 A
 Series circuit 24 V / 2.63 A
 Short-circuit proof with PTC

6 TE

	ARTICLE NO.	WEIGHT g/EACH	PACKING UNIT
63 VA	ST63	1731	2

63 VA	ST63	1731	2
-------	-------------	------	---

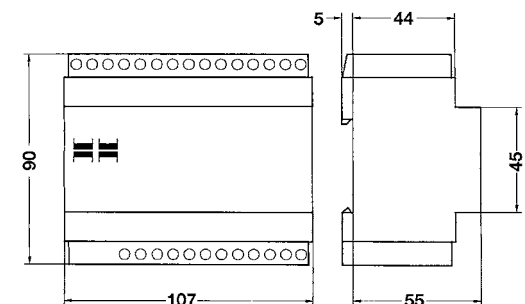

DIN-RAIL PANEL PRODUCTS

LOMO logic module



LOMOcompact LOGIC MODULE

Inputs:
 8 x digital (180-264 V)
 2 x analogue (0-10 V)
 Switching outputs:
 5 x 230 V~/30 V = 5 A floating
 DC output: 1 x 11.3 V 280 mA

ARTICLE NO.	WEIGHT g/EACH	PACKING UNIT
-------------	---------------	--------------

LOM8522	260	1
---------	-----	---



LOMO 552 EXPANSION MODULE

Inputs:
 5 x digital (180-264 V)
 2 x analogue (0-10 V)
 Switching outputs:
 5 x 230 V~/30 V = 5 A floating

ARTICLE NO.	WEIGHT g/EACH	PACKING UNIT
-------------	---------------	--------------

LOM5521	176	1
---------	-----	---

Technical Data / Type			
Interfaces			
	LoMo852	LoMo552	
Digital inputs	8	5	180-264 V~ galvanically separated
Switching outputs	5	5	230 V~/30 V= 5 A floating
Analogue inputs	2	2	0-10 V
RS232	1	1	
DC output	1	0	11.3 V 280 mA

Nominal voltage	
LoMo 852	230 V~ 50 Hz
LoMo 552	12 V= 120 mA

Ambience	
Ambient storage temperature	-30 ... 85 °C
Ambient working temperaturer	-20 ... 55 °C
Relative humidity	10 ... 90% (without condensation)
Protection class	II
Overvoltage category	II
Degree of protection	IP20
Housing	6M (LoMo 852) on DIN-rail 35 mm 4M (LoMo 552) on DIN-rail 35 mm

DIN-RAIL PANEL PRODUCTS

LOMO accessories



TOUCHSCREEN DISPLAY

Display: 7" TFT 800 x 480 (WVGA)
4wire, resistive touchscreen
Interface: RS232 & RS485
Protection rating: IP20 (LOMD112)
or IP65 (LOMD212)

User programmable GUI and functions (via script)

ARTICLE NO.	PACKING UNIT
-------------	--------------

LOMD112	1
LOMD212	1



LOMware Software

Programming application for LOMOcompact

ARTICLE NO.	PACKING UNIT
-------------	--------------

LOMW100	1
---------	---

POWER CORD for Touchscreen Display

ARTICLE NO.	LENGTH CM	PACKING UNIT
-------------	-----------	--------------

LOMK430	300	1
---------	-----	---

PROGRAMMING CABLE

ARTICLE NO.	LENGTH CM	PACKING UNIT
-------------	-----------	--------------

LOMK218	180	1
---------	-----	---

CONNECTION CABLE LOMOcompact to Touchscreen Display

ARTICLE NO.	LENGTH CM	PACKING UNIT
-------------	-----------	--------------

LOMK330	330	1
---------	-----	---

ABL SURSUM

I_e 4-6,3A

U_e 690V



WS6.3

Stop

Start



1000 1000
1000 1000
1000 1000



SWITCHING DEVICES

MOTOR PROTECTIVE CIRCUIT BREAKERS

Motor Protective Circuit Breakers MS	102
Motor Protective Circuit Breakers MS/BS	103
Transformer Protective Circuit Breakers MST	104
Motor Protective Circuit Breakers MSH/MSW	105
Motor Protective Devices for variable-speed fan motors	106
Accessories	107
Technical Data	113
Motor Protective Circuit Breakers MA	116
Accessories	118
Busbars	118
Technical Data	120

MOTOR PROTECTIVE CIRCUIT BREAKERS MS

Overview



MOTOR PROTECTIVE CIRCUIT BREAKERS MS/BS

acc. to IEC 60947-4-1, UL 508

The MS motor protective circuit breakers offer optimal protection for motors and other loads up to 32 A, due to its high breaking capacity with strongly limited current.

They are equipped with phase failure sensitivity, isolating and main switch functions; 14 ranges are covering nominal rated currents from 0.1 up to 32 A.

The MPCBs are self protected up to 6.3 A at 400 V. Ranges > 6.3 A provide a short circuit withstand rating of 6 kA. The MPCBs are temperature compensated; the actuating current of the short circuit trip is $12 \times I_n$.

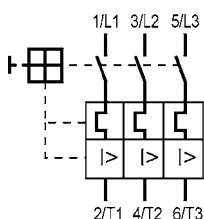

FILE E 137938



RATED CURRENT A	MAX. RATED OPERATING POWER (kW/AC 3)			OPERATING CURRENT SHORT CIRCUIT TRIP (A)	ARTICLE NO.	WEIGHT g/EACH	PACKING UNIT
	400/415 V	500 V	690 V				

MS with overload and short circuit tripping							
Phase failure sensitivity							
0.1 – 0.16	–	–	0.06	1.92	MS016	250	1
0.16 – 0.25	0.06	0.06	0.12	3	MS025	250	1
0.25 – 0.4	0.09	0.12	0.18	4.8	MS04	250	1
0.4 – 0.63	0.12	0.18	0.25	7.6	MS063	250	1
0.63 – 1	0.25	0.37	0.55	12	MS1	250	1
1 – 1.6	0.55	0.75	1.1	19.2	MS1.6	250	1
1.6 – 2.5	0.75	1.1	1.5	30	MS2.5	250	1
2.5 – 4	1.5	2.2	3	48	MS4	250	1
4 – 6.3	2.2	3	4	75.6	MS6.3	250	1
6.3 – 10	4	5.5	7.5	120	MS10	250	1
10 – 16	7.5	9	12.5	192	MS16	250	1
16 – 20	9	12.5	15	240	MS20	250	1
20 – 25	12.5	15	22	300	MS25	250	1
25 – 32	15	18.5	–	384	MS32	250	1

*32 A without VDE, without UL-approval

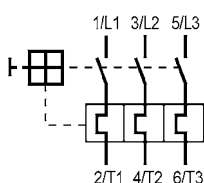

RATED CURRENT A	MAX. RATED OPERATING POWER (kW/AC 3)			OPERATING CURRENT SHORT CIRCUIT TRIP (A)	ARTICLE NO.	WEIGHT g/EACH	PACKING UNIT
	400/415 V	500 V	690 V				

0.4 – 0.63	0.12	0.18	0.25		BS063	230	1
0.63 – 1	0.25	0.37	0.55		BS1	230	1
1 – 1.6	0.55	0.75	1.1		BS1.6	230	1
1.6 – 2.5	0.75	1.1	1.5		BS2.5	230	1
2.5 – 4	1.5	2.2	3		BS4	230	1
4 – 6.3	2.2	3	4		BS6.3	230	1
6.3 – 10	4	5.5	7.5		BS10	230	1
10 – 16	7.5	9	12.5		BS16	230	1
16 – 20	9	12.5	15		BS20	230	1
20 – 25	12.5	15	22		BS25	230	1
25 – 32	15	18.5	-		BS32	230	1

*32 A without VDE-approval

TRANSFORMER PROTECTIVE CIRCUIT BREAKERS MST

acc. to IEC 60947-4-1

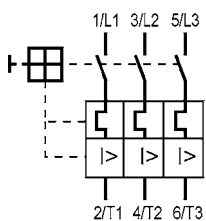

RATED CURRENT A	MAX. RATED OPERATING POWER (kW/AC 3)			OPERATING CURRENT SHORT CIRCUIT TRIP (A)	ARTICLE NO.	WEIGHT g/EACH	PACKING UNIT
	400/415 V	500 V	690 V				

MST with overload and short circuit tripping for transformers with high inrush currents							
0.1 – 0.16	–	–	–	3.2	MST016	250	1
0.16 – 0.25	–	0.16	–	5	MST025	250	1
0.25 – 0.4	0.16	0.25	0.25	8	MST04	250	1
0.4 – 0.63	0.25	0.4	0.4	12.6	MST063	250	1
0.63 – 1	0.4	0.63	1	20	MST1	250	1
1 – 1.6	0.63	1	–	32	MST1.6	250	1
1.6 – 2.5	1	1.6	2	50	MST2.5	250	1
2.5 – 4	1.6/1	2.5	2.5	80	MST4	250	1
4 – 6.3	2.5	4	6.3	126	MST6.3	250	1
6.3 – 10	4.0/5.0	6.3	–	200	MST10	250	1
10 – 16	6.3/8	10	10	320	MST16	250	1
16 – 20	12.5	16	–	400	MST20	250	1
20 – 25	12.5	16	–	500	MST25	250	1

MOTOR PROTECTIVE CIRCUIT BREAKERS MSH/MSW

acc. to IEC 60947-4-1

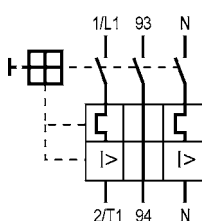

RATED CURRENT A	MAX. RATED OPERATING POWER				OPERATING CURRENT SHORT CIRCUIT TRIP (A)	ARTICLE NO.	WEIGHT g/EACH	PACKING UNIT
	CB 230 V 15001/min	CB 230 V 30001/min	CA + CB 230 V 15001/min	CA + CB 230 V 30001/min				

MSH für Wechselstrommotoren mit Hilfsschalter, mit Überlast- und Kurzschlussauslösern

0,63 – 1	0,07	0,09	–	–	12	MSH1	220	1
1 – 1,6	0,12	0,12/0,18	0,12	0,18	19,2	MSH1.6	220	1
1,6 – 2,5	0,18	0,3	0,18/0,87	0,25	30	MSH2.5	220	1
2,5 – 4	0,22	0,5/0,55	0,37/0,5	0,37/0,66	48	MSH4	220	1
4 – 6,3	0,55/0,75	0,55/0,75	0,65	0,75/1,0	75,6	MSH6.3	220	1
6,3 – 10	1,0/1,3	1,1/1,3	1,0/1,3	1,0/1,3	120	MSH10	220	1
10 – 16	1,5 – 2,2	1,75	1,5	1,75	192	MSH16	220	1
16 – 20	–	–	–	–	240	MSH20	220	1

CB with operating capacitor

CA with starting capacitor and CB with operating capacitor

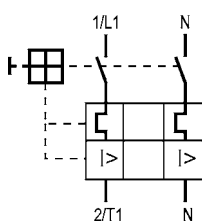

RATED CURRENT A	MAX. RATED OPERATING POWER				OPERATING CURRENT SHORT CIRCUIT TRIP (A)	ARTICLE NO.	WEIGHT g/EACH	PACKING UNIT
	CB 230 V 15001/min	CB 230 V 30001/min	CA + CB 230 V 15001/min	CA + CB 230 V 30001/min				

MSW for AC motors with overload and short circuit tripping

0.63 – 1	0.07	0.09	–	–	12	MSW1	210	1
1 – 1.6	0.12	0.12/0.18	0.12	0.18	19.2	MSW1.6	210	1
1.6 – 2.5	0.18	0.3	0.18/0.87	0.25	30	MSW2.5	210	1
2.5 – 4	0.22	0.5/0.55	0.37/0.5	0.37/0.66	48	MSW4	210	1
4 – 6.3	0.55/0.75	0.55/0.75	0.65	0.75/1.0	75.6	MSW6.3	210	1
6.3 – 10	1.0/1.3	1.1/1.3	1.0/1.3	1.0/1.3	120	MSW10	210	1
10 – 16	1.5 – 2.2	1.75	1.5	1.75	192	MSW16	210	1
16 – 20	–	–	–	–	240	MSW20	210	1

CB with operating capacitor

CA with starting capacitor and CB with operating capacitor

MOTOR PROTECTIVE DEVICES FOR VARIABLE-SPEED FAN MOTORS



CURRENT OPERATING RANGE (A)	ARTICLE NO.	WEIGHT g/EACH	PACKING UNIT
-----------------------------	-------------	---------------	--------------

Motor protection for variable-speed fan motors			
0,4-10	MWC10	190	1

The MWC 10 is a multi-polar circuit breaker which allows a thermal contact, which is built into the motor (directly into the coil), to be analysed.

For example, if the motor is hindered due to dirt, the coil will heat up more than normal and the thermal contact (NC contact) in the coil will break the circuit.

The bimetal built into the circuit breaker recognizes the opening of the thermal contact in the motor coil and, with the smallest motor rated current, switches off all poles completely within max. 40 s.

However, this type of full motor protection neglects wiring protection. The connection from the full motor protection to the fan is not protected.

In order to protect this connection, a back-up fuse is needed which fits the conductor cross section. This back-up fuse is usually installed in front of the full motor protection.

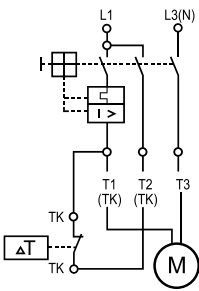

Motor protection for variable-speed fan motors including wiring protection			
1,6 – 2,5	MSWC2.5	220	1
2,5 – 4,0	MSWC4	220	1
4,0 – 6,3	MSWC6.3	220	1

These 3 devices combine the function of the MWC 10 (evaluation unit for the thermal contact) with a motor protective circuit breaker for AC use (phase - neutral).

The trips for the thermal and electromagnetic tripping of the motor protective circuit breakers are in the first and third conducting paths. The evaluating bimetal for the thermal contact is in the middle conducting path of the circuit breaker.

This combined device provides optimal protection for loads by combining the normal protection of the motor protective circuit breaker with analysis by the thermal contact. This combination of motor protective circuit breaker with full motor protection **inherently stabilizes** the motor up to rated currents of 6.3 A at a mains voltage of up to 230 V AC. This means that **no additional back-up fuse** is needed.

A full motor protection for motor protective circuit breakers in connection with variable-speed fan motors is only possible by monitoring the coil temperature by means of thermal contacts installed in the motor. Therefore, the manufacturers of fan motors recommend using full motor protective devices of type MWC10 or MSWC...

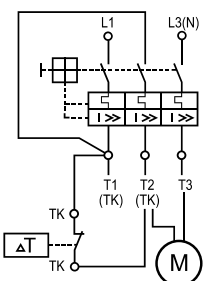

ACCESSORIES FOR MOTOR PROTECTIVE CIRCUIT BREAKERS MS

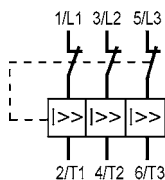

RATED UNINTERRUPTED CURRENT (A)	ARTICLE NO.	WEIGHT G / EACH	PACKING UNIT
---------------------------------	-------------	-----------------	--------------

Current limiter increasing the short circuit withstand rating of not inherent stable MPCBs up to 50 kA at 400 volts area

32	SBMS32	175	1
----	--------	-----	---



FILE E 137938



MODULES	WIRING DIAGRAM	CONTACTS	ARTICLE NO.	WEIGHT g / EACH	PACKING UNIT
---------	----------------	----------	-------------	-----------------	--------------

Hilfsschalter zum seitlichen Anbau

1/2 M		2 NO	HMS20	40	5
1/2 M		1 NO + 1 NC	HMS11	40	5
1/2 M		1 NO	HMS10	40	5
1/2 M		2 NC	HMS02	40	5
1/2 M		1 NC	HMS01	40	5



Early make auxiliary contact for side mounting					
MODULES	WIRING DIAGRAM	CONTACTS	ARTICLE NO.	WEIGHT g / EACH	PACKING UNIT
1/2 M		1 NO + 1 NC	VHMS11	40	5
1/2 TE		2 NO	VHMS20	40	5

ACCESSORIES FOR MOTOR PROTECTIVE CIRCUIT BREAKERS MS



	WIRING DIAGRAM	CONTACTS	ARTICLE NO.	WEIGHT g/EACH	PACKING UNIT
--	----------------	----------	-------------	---------------	--------------

Trip-indicating auxiliary contact for inside mounting

		1 NO	SHMS10	25	10
		1 NC	SHMS01	25	10



Auxiliary contact for front mounting					
		1 NO + 1 NC	FHMS11	13	10
		1 NO	FHMS10	11	10
		1 NC	FHMS01	11	10

Can not be used together with EHMS, SHMS, AMS and UMS.

Technical Data	HMS, VHMS	FHMS	SHMS
Rated impulse withstand voltage U_{imp}	4 000 V		
Rated operating voltage U_e	500 V	250 V	500 V
Overvoltage category/Pollution level	III/3	III/3	III/3
Max. current (with free air circulation) I_{th}	6A	5A	6A
Rated operating current I_e	3.5/2 A	1 A/-	2/1 A
Can also be used for low voltage and PLC-inputs	24 V DC, 10 mA		
Cross section: 1 conductor mm ² 2 conductor mm ² only HMS, VHMS	0.75 – 2.5 r; 0.75 – 1.5 f (with ferrule) 0.75 – 2.5 r; 0.75 – 1.5 f (with ferrule)		

It is possible to equip the breakers with different auxiliary contacts. Auxiliary contacts HMS, FHMS and EHMS operate in accordance with the main contacts. They are designed for remote signaling, electrical interlocking and control applications. Early make contacts VHMS operate earlier than the main contacts. Trip-indicating auxiliary contacts SHMS operate in case of a fault.

ACCESSORIES FOR MOTOR PROTECTIVE CIRCUIT BREAKERS MS



FILE E 137938

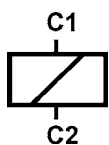

	RATED OPERATING VOLTAGE	ARTICLE NO.	WEIGHT g/EACH	PACKING UNIT
--	-------------------------	-------------	---------------	--------------

Shunt trip for inside mounting with connecting cable (140 mm long)				
	110 V 50 Hz, 120 V 60 Hz	AMS110	75	10
	220-230V 50 Hz, 240 V 60 Hz	AMS220	75	10
	380-415 V 50 Hz, 440 V 60 Hz	AMS380	75	10
	24 V 50/60 Hz	AMS24	75	10
	500 V 50 Hz	AMS500	75	10
	24 V DC	AMSD24	75	10
Pull-in voltage $0,7 \times U_e$			Switch in duration for U_e 100% AC	

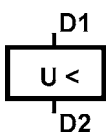

Undervoltage trip for inside mounting with connecting cable (140 mm long)				
	110 V 50 Hz, 120 V 60 Hz	UMS110	75	10
	220-230 V 50 Hz, 240 V 60 Hz	UMS220	75	10
	380-415 V 50 Hz, 440 V 60 Hz	UMS380	75	10
	24 V 50/60 Hz	UMS24	75	10
	500 V 50 Hz	UMS500	75	10
Pull-in voltage $\geq 0.85 \times U_e$		Drop out voltage $0,35-0,7 \times U_e$		Switch in duration for U_e 100%

ACCESSORIES FOR MOTOR PROTECTIVE CIRCUIT BREAKERS MS



INSULATED ENCLOSURE IP41
with integrated PE(N)
terminal top and bottom each
2 metric knock-outs

	ARTICLE NO.	WEIGHT g/EACH	PACKING UNIT
--	-------------	---------------	--------------

	MS.G41	220	1
--	---------------	-----	---



INSULATED ENCLOSURE WITH
IP54 SCHUKO EARTHED PLUG
with 2 earthing systems
acc. to CEE7/VII
16 A 250 V, 2-pole + ⊕
1 opening at the bottom

NO. OF POLES	ARTICLE NO.	WEIGHT g/EACH	PACKING UNIT
--------------	-------------	---------------	--------------

2-pole+ ⊕	MS.C21	410	1
--------------	---------------	-----	---



INSULATED ENCLOSURE IP55
with integrated PE(N)
terminal top and bottom each
2 metric knock-outs

	ARTICLE NO.	WEIGHT g/EACH	PACKING UNIT
--	-------------	---------------	--------------

	MS.G55	240	1
--	---------------	-----	---



INSULATED ENCLOSURE
WITH CEE-PLUG IP54
16 A 400 V
1 opening at the bottom

NO. OF POLES	ARTICLE NO.	WEIGHT g/EACH	PACKING UNIT
--------------	-------------	---------------	--------------

5-pole	MS.C51	420	1
4-pole	MS.C41	415	1
3-pole	MS.C31	410	1



INSULATED FLUSH MOUNTING
ENCLOSURE IP41
with integrated PE(N) terminal

	ARTICLE NO.	WEIGHT g/EACH	PACKING UNIT
--	-------------	---------------	--------------

	MS.F41	150	1
--	---------------	-----	---



INSULATED ENCLOSURE WITH
CEE-PLUG IP54 AND PHASE-IN-
VERTER
16 A 400 V
1 opening at the bottom

NO. OF POLES	ARTICLE NO.	WEIGHT g/EACH	PACKING UNIT
--------------	-------------	---------------	--------------

5-pol.	MS.P51	420	1
--------	---------------	-----	---



INSULATED FLUSH MOUNTING
ENCLOSURE IP55
with integrated PE(N) terminal

	ARTICLE NO.	WEIGHT g/EACH	PACKING UNIT
--	-------------	---------------	--------------

	MS.F55	170	1
--	---------------	-----	---

ACCESSORIES FOR MOTOR PROTECTIVE CIRCUIT BREAKERS MS



STOP BUTTON
not latching
red, on grey surface

	ARTICLE NO.	WEIGHT g / EACH	PACKING UNIT
	MS.PT	55	5

	MS.PT	55	5
--	-------	----	---



PADLOCKING FACILITY
for up to three padlocks

	ARTICLE NO.	WEIGHT g / EACH	PACKING UNIT
	MS.VS	100	10

	MS.VS	100	10
--	-------	-----	----



EMERGENCY-STOP BUTTON
latching, turn to release
red, on yellow surface

	ARTICLE NO.	WEIGHT g / EACH	PACKING UNIT
	MS.PV	60	5

	MS.PV	60	5
--	-------	----	---



KIT IP55
to increase degree of protection
from IP41 to IP55

	ARTICLE NO.	WEIGHT g / EACH	PACKING UNIT
	MS.BS	25	10

	MS.BS	25	10
--	-------	----	----



EMERGENCY-STOP BUTTON
latching, key release (2 keys)
red, on yellow surface

	ARTICLE NO.	WEIGHT g / EACH	PACKING UNIT
	MS.PS2	65	5

	MS.PS2	65	5
--	--------	----	---



N-TERMINAL
connecting of fifth conductor

	ARTICLE NO.	WEIGHT g / EACH	PACKING UNIT
	MS.N	10	10

	MS.N	10	10
--	------	----	----



INDICATOR LIGHT
with glow bulb,
nominal rated voltage: 220-240 V

COLOUR	ARTICLE NO.	WEIGHT g / EACH	PACKING UNIT
transp.	MS.SLW2	10	5
green	MS.SLG2	10	5
red	MS.SLR2	10	5
yellow	MS.SLJ2	10	5

transp.	MS.SLW2	10	5
green	MS.SLG2	10	5
red	MS.SLR2	10	5
yellow	MS.SLJ2	10	5



INDICATOR LIGHT
with glow bulb,
nominal rated voltage: 380-440 V

COLOUR	ARTICLE NO.	WEIGHT g / EACH	PACKING UNIT
transp.	MS.SLW3	10	5
green	MS.SLG3	10	5
red	MS.SLR3	10	5
yellow	MS.SLJ3	10	5

transp.	MS.SLW3	10	5
green	MS.SLG3	10	5
red	MS.SLR3	10	5
yellow	MS.SLJ3	10	5

ACCESSORIES FOR MOTOR PROTECTIVE CIRCUIT BREAKERS MS

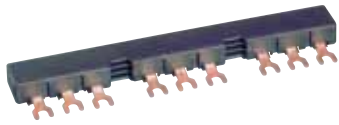

DESCRIPTION	MAX. BUSBAR CURRENT (A)	LENGTH	ARTICLE NO.	WEIGHT g/EACH	PACKING UNIT
-------------	-------------------------	--------	-------------	---------------	--------------

Busbars					
for 2 MPCBs without auxiliary contacts	63	90 mm	SB.D02	37	10
for 3 MPCBs without auxiliary contacts	63	136 mm	SB.D03	55	10
for 4 MPCBs without auxiliary contacts	63	180 mm	SB.D04	75	10
for 2 MPCBs each with 1 auxiliary contact fitted on the right side	63	99 mm	SB.D12	40	10
for 3 MPCBs each with 1 auxiliary contact fitted on the right side	63	153 mm	SB.D13	65	10
for 4 MPCBs each with 1 auxiliary contact fitted on the right side	63	207 mm	SB.D14	90	10
for 5 MPCBs each with 1 auxiliary contact fitted on the right side	63	261 mm	SB.D15	115	10
for 2 MPCBs each with 2 auxiliary contacts	63	108 mm	SB.D22	45	10
for 4 MPCBs each with 2 auxiliary contacts	63	234 mm	SB.D24	105	10

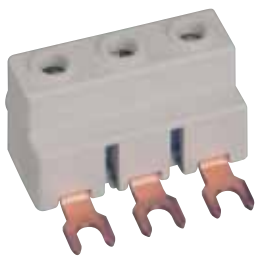

Incoming terminal block					
	63		SB.DE1	30	10



Shroud					
			SB.DA1	5	10

MOTOR PROTECTIVE CIRCUIT BREAKERS MS

Technical Data

Standards	IEC 60947-4-1, DIN EN 60947-4-1, VDE 0660-102
Mechanical endurance	5000 switching cycles
Electrical endurance	1000 switching cycles
Max. operating frequency	30 switching cycles / h
Ambient temperature not enclosed, max./min. enclosed, max./min.	-20°C to +55°C -20°C to 40°C
Resistance to mechanical shocks	15 g / 10 ms
Installation position	any, in IP41 enclosure vertical
Cross section (1 or 2 conductors)	1.0 – 6 r; 0.75 – 4 f (with ferrule) 2 conductors differing by not more than 2 sizes
Torque for terminal screws · Main conductor · Auxiliary conductor · Auxiliary contact for front mounting	1.2 Nm 1.0 Nm 0.5 Nm
Rated impulse withstand voltage U_{imp}	6 000 V
Overvoltage category / Pollution level	III / 3
Rated operating voltage U_e	690 V AC
Rated operating current I_e	0.16 – 32 A according to setting range
Frequency	40...60 Hz
	At higher frequencies, the electromagnetic tripping values rise by a factor of about 1.1 at 100 Hz; 1.2 at 200 Hz; 1.4 at 400 Hz; 1.5 at 500 Hz
Utilization category (IEC 60947-4-1, DIN EN 60947-4-1, VDE 0660-102)	AC-3 max. 690 V
Temperature compensation (reference values to VDE / IEC)	-5°C / +40°C
Temperature compensation Operating range	-20°C...+55°C
Power loss in watt per path of current	by min. setting range 0.6 – 1.05 W / by max. setting range 1.5 – 2.6 W

Rated short circuit withstand rating I_{cu} MS IEC 60947-2, DIN EN 60947-2, VDE 0660-101

UPPER SETTING THERMAL TRIPPING	I_{cu} (kA)				CURRENT LIMITER SBMS32 · I_{cu} (kA)	
	230 V	400 V	500 V	690 V	230 V	400 V
0,16 – 1,6 A	No additional protective devices needed inherently stable for any selected short circuit currents				No additional protective devices needed inherently stable for any selected short circuit currents	
2,5 – 6,3 A			3	2,5		
10 A		6	3	2,5		50
16 – 32 A	10	6	2,5	2	100	50

Switching times at short circuit
 minimum command time 2 ms
 opening delay 2 ms
 opening time 7 ms

MOTOR PROTECTIVE CIRCUIT BREAKERS MS

Technical Data

Back-up-protection MS (if the short circuit current is higher than the short circuit withstand rating of MS)

RATED CURRENT	BACK-UP FUSE (gL, aM) (A)			
	230 V	400 V	500 V	690 V
0,1 - 0,16 A	No back-up fuse necessary inherently stable for any selected short circuit currents			
0,16 - 0,25 A				
0,25 - 0,4 A				
0,4 - 0,63 A				
0,63 - 1 A				
1 - 1,6 A				
1,6 - 2,5 A			25	20
2,5 - 4 A			35	25
4 - 6,3 A			50	35
6,3 - 10 A		80	50	35
10 - 16 A	80	80	63	35
16 - 20 A	80	80	63	50
20 - 25 A	80	80	63	50
25 - 32 A	80	80	63	50

Back-up-protection BS

RATED CURRENT (A)	FUSE (A)	RATED CURRENT (A)	FUSE (A)	RATED CURRENT (A)	FUSE (A)
0,4 - 0,63	2	2,5 - 4	10	16 - 20	50
0,63 - 1	4	4 - 6,3	16	20 - 25	50
1 - 1,6	6	6,3 - 10	25	25 - 32	50
1,6 - 2,5	6	10 - 16	35		

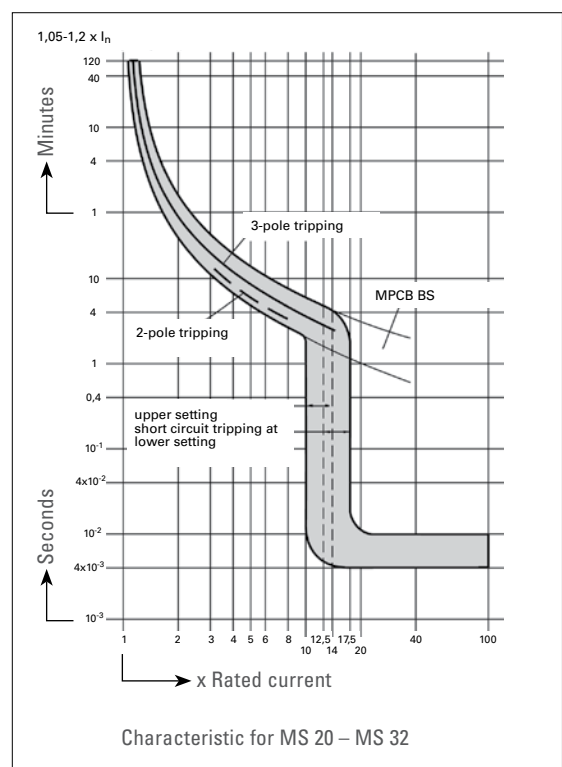
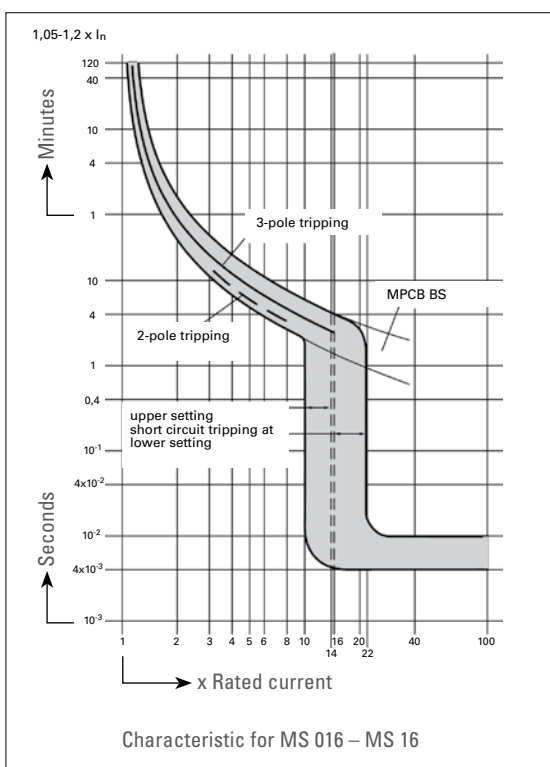

MOTOR PROTECTIVE CIRCUIT BREAKERS MS

Dimension Drawings

Motor protective circuit breaker MS

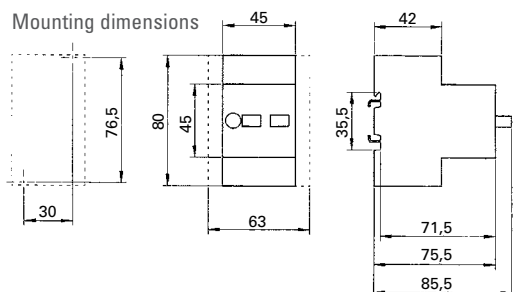

Current limiter SBMS32

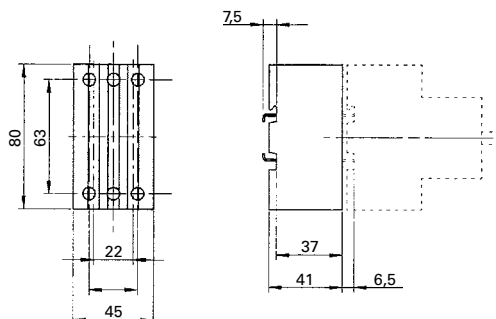

Insulated enclosure IP41 / IP55 MS.G41 / MS.G55

possible to integrate 1 MPCB
and 2 side mounted auxiliary contacts

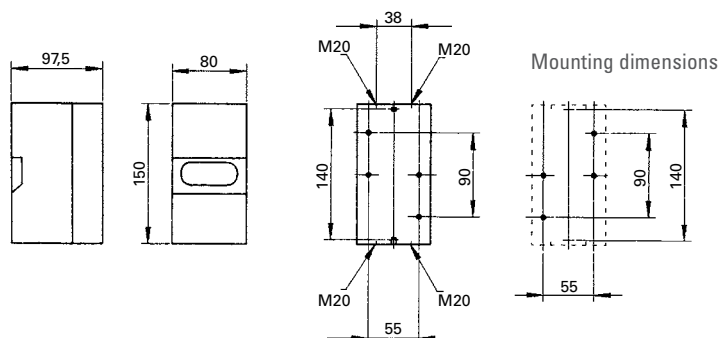

Insulated flush mounting enclosure MS.F41 / MS.F55

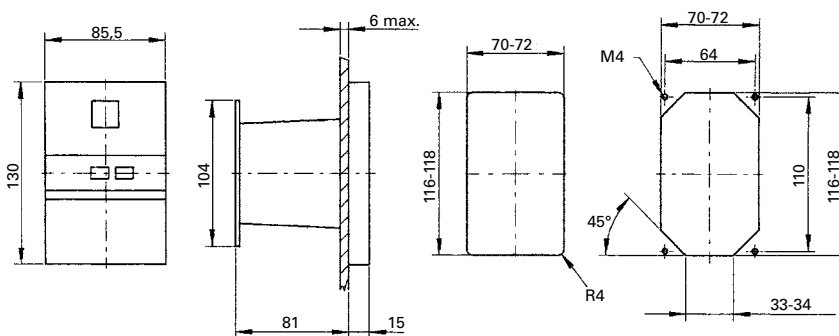

Insulated enclosure with CEE plug

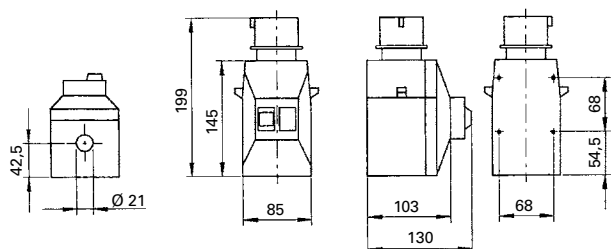

Emergency-stop button MS.PT – PS.PS2

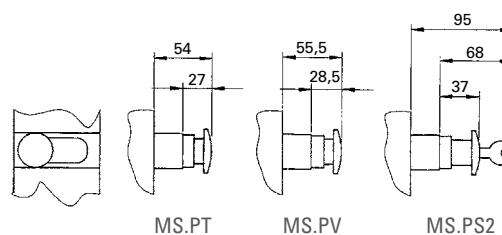

MOTOR PROTECTIVE CIRCUIT BREAKERS MA

Overview

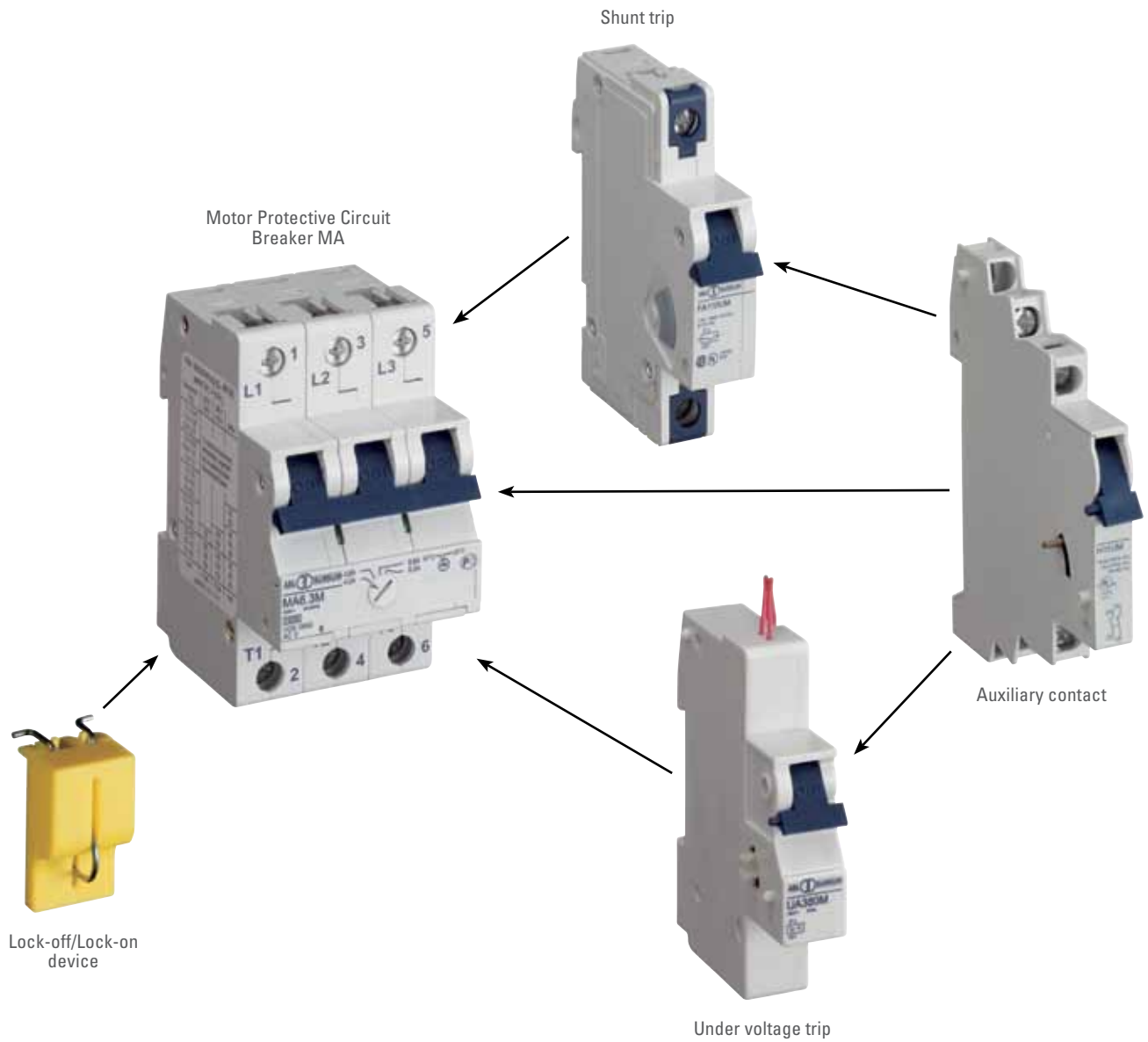

MOTOR PROTECTIVE CIRCUIT BREAKERS MA

IEC 60947

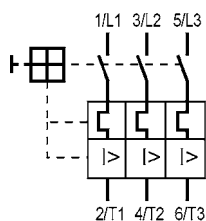

RATED CURRENT [A]	MAX. RATED OPERATING POWER (KW/AC 3)			OPERATING CURRENT SHORT CIRCUIT TRIP [A]	ARTICLE NO.	WEIGHT G / EACH	PACKING UNIT
	400/415 V	500 V	690 V				

MA mit Überlast- und Kurzschlussauslösern 40°C — 20°C
 Temperaturkompensation von +20°C bis +40°C einstellbar

0,1 – 0,16	–	–		1,92	MA016M	450	1
0,16 – 0,25	0,06	0,06		3	MA025M	450	1
0,25 – 0,4	0,09	0,12		4,8	MA040M	450	1
0,4 – 0,63	0,12	0,25		7,6	MA063M	450	1
0,63 – 1	0,25	0,37		12	MA1.0M	450	1
1 – 1,6	0,55	0,75		19,2	MA1.6M	450	1
1,6 – 2,5	0,75	1,1		30	MA2.5M	450	1
2,5 – 4	1,5	2,2		48	MA4.0M	450	1
4 – 6,3	2,2	3		75,6	MA6.3M	450	1
6,3 – 10	4	4		120	MA10M	450	1
10 – 16	7,5	9		192	MA16M	450	1
16 – 20	9	12,5		240	MA20M	450	1
20 – 25	12,5	15		300	MA25M	450	1
25 – 32	15	18,5		348	MA32M	450	1
32 – 40	18,5	22		480	MA40M	450	1

ACCESSORIES

for motor protective circuit breakers MA



Shunt trip					
MODULE	RATED OPERATING VOLTAGE	MAX. OPERATING CURRENT AT U_n ($t < 10$ ms)	ARTICLE NO.	WEIGHT g/EACH	PACKING UNIT
1	12 V \approx	1,3 A	FA12UM	105	5
1	24 V \approx	0,6 A	FA24UM	105	5
1	48 - 72 V \approx	0,2 A	FA48UM	105	5
1	110 - 240 V \approx , 415 V \sim	0,25 A at 110 V	FA110UM	105	5
		0,5 A at 240 V			
		0,8 A at 415 V			
Pull-in voltage $0.7 \times U_e$			Switch in duration for U_e 100%		



Undervoltage trip (50 Hz)					
MODULE	RATED VOLTAGE		ARTICLE NO.	WEIGHT g/EACH	PACKING UNIT
1	24 V		UA24M	150	5
1	110 V		UA110M	150	5
1	220 V		UA220M	150	5
1	240 V		UA240M	150	5
1	380 V		UA380M	150	5
1	415 - 440 V		UA415M	150	5
Pull-in voltage $\geq 0.85 \times U_e$		Drop out voltage $0.35 - 0.7 \times U_e$		Switch in duration for U_e 100%	



Busbars						
CROSS SECTION (mm ²)	BUSBAR CURRENT START OF BUSBAR/MIDDLE INFEED	MODULES/ PHASES	ARTICLE NO.	WEIGHT g/EACH	PACKING UNIT	PASSENDE ENDKAPPE ART.-NR.
3 phase						
10	63/100	4/3	SB31210	84	25	SB.A1
10	63/100	19/3	SB36010	420	20	SB.A1
16	80/130	19/3	SB36016	675	20	SB.A2
3 phase 3-pole circuit breaker + auxiliary contact						
16	80/130	16/3	SB36316	630	20	SB.A2



DISTANCE DEVICE 9 MM

MODULE	ARTICLE NO.	WEIGHT g/EACH	PACKING UNIT
1/2	HDS	7	10



LOCK-OFF/LOCK-ON DEVICE

For miniature circuit breakers and motor protective circuit breakers

ARTICLE NO.	WEIGHT g/EACH	PACKING UNIT
EASS	4	10

ACCESSORIES

for motor protective circuit breakers MA



Auxiliary contact

MODULE	TYPE OF CONTACT	CONTACTS	ARTICLE NO.	WEIGHT g/EACH	PACKING UNIT
1/2	1 auxiliary contact	1NO	H10UM	35	10
1/2	2 auxiliary contacts	1NO + 1NC	H11UM	40	10
1/2	3 auxiliary contacts	1NO + 2NC	H12UM	45	10
1/2	3 auxiliary contacts	2NO + 1NC	H21UM	45	10

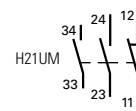
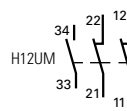
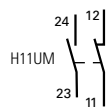

Standards	according to IEC 60947-5-1, DIN EN 60947-5-1, VDE 0660-200, UL 508	
Rated operating currents	10 A / 240 V AC 3 A / 110 V DC 1 A / 220 V DC	
Minimum contact load	1 mA at 24 V DC	
Conductor cross sections		
Type of conductor *)	min.	max.
Single wire	0.5 mm ²	2.5 mm ²
Stranded wire	0.5 mm ²	1.5 mm ²
Stranded wire with ferrule	0.5 mm ²	1.5 mm ²
Torque	max. 0.8 Nm	

*) Stripped length 8 - 9 mm

MOTOR PROTECTIVE CIRCUIT BREAKERS MA

Technical Data		
Standards	IEC 60947-2, DIN EN 60947-2, VDE 0660-101 IEC 60947-4-1, DIN EN 60947-4-1, VDE 0660-102 DIN VDE 0100, DIN VDE 0110, DIN VDE 0113	
Short circuit withstand rating	10 kA at 240/415 V~	
Utilization category	AC 3 at U_e 415 V~ (up to I_n 25 A)	
Max. back-up fuse	Fuse according to DIN-VDE 0636 100 A operating class gL for 240/415 V~ (only for $I_n > 10$ A)	
Rated voltage	500 V~ / 50-60 Hz	
Rated current range	15 setting ranges from 0.1 up to 40 A	
Rated uninterrupted current I_{th}	40 A	
Tripping time at $6 \times I_e$	> 5s/TII	
Test currents	Thermal not tripping I_1 (A) > 2 h	$1.05 \times I_e$
	Thermal tripping I_2 (A) < 2 h	$1.2 \times I_e$
	Electromagnetic not tripping I_4 (A) > 0.1 s	for the lower setting $16 \times I_e$ ($12.5 \times I_e > 16$ A) for the upper setting $10 \times I_e$
	Electromagnetic tripping I_5 (A) < 0.1 s	for the lower setting $19 \times I_e$ ($15 \times I_e > 16$ A) for the upper setting $12 \times I_e$
Temperature compensation	up to +40°C	
Permitted ambient temperature	open -20°C to +50°C, enclosure -20°C to +40°C storage/transport -40°C to +70°C	
Device depth according to DIN 43880	68 mm	
Mechanical endurance	30 000 switching cycles (30 000 ON / 30 000 OFF)	
Permitted operating frequency	30 switching cycles / h	
Protection cover	Safe for fingers and back of hand acc. to DIN EN 50274, VDE 0660-514 BGV A2	
Degree of protection according to EN/IEC 60529	IP20	
Installation position	any	
Mounting	On DIN-rail acc. to DIN EN 60715 35 mm	
Lockability	The handle can be secured against manual switching in the on and off position by a lead seal	
Climatic resistance	Humid heat constant according to DIN IEC 60068-2 – 78 Humid heat cyclic according to DIN EN 60068-2 – 30	
Vibration resistance	> 15 g according to DIN EN 60068-2 – 59 for a load with I_1	
Resistance to mechanical shocks	25 g 11 ms	

MOTOR PROTECTIVE CIRCUIT BREAKERS MA

Conductor cross sections

	BOX TERMINAL BOTTOM		BOX TERMINAL TOP	
Type of conductor *)	max.	min.	max.	min.
Single wire	25 mm ²	0.5 mm ²	25 mm ²	0.5 mm ²
Multiple wire	25 mm ²	(16 mm ²)	25 mm ²	(16 mm ²)
Stranded wire	16 mm ²	0.5 mm ²	16 mm ²	0.5 mm ²
Stranded wire with ferrule	16 mm ²	0.5 mm ²	16 mm ²	0.5 mm ²
Busbar Cable lug	up to 3 mm thickness		up to 1.5 mm thickness	
Combined, conductor and busbar or cable lug	up to 25 mm ² and up to 2 mm thickness		not possible	
Torque	max. 2.5 Nm			

*) Stripped length: bottom 12 - 14 mm, top 10 - 12 mm

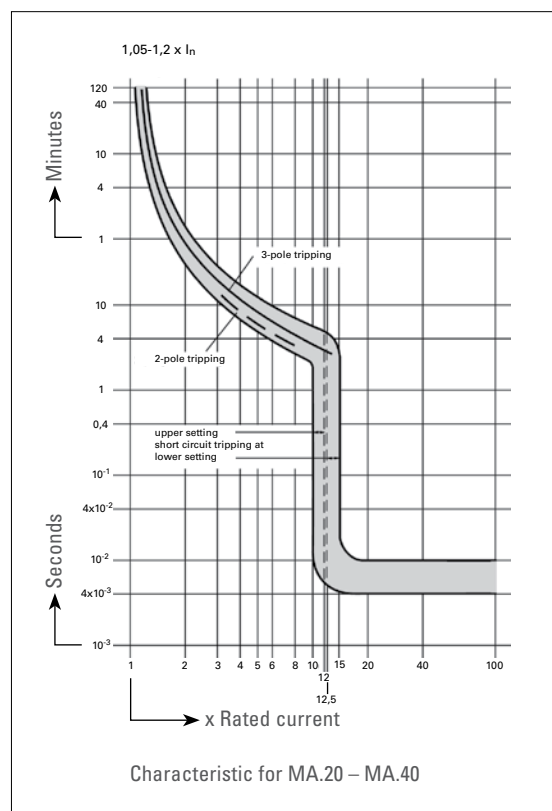
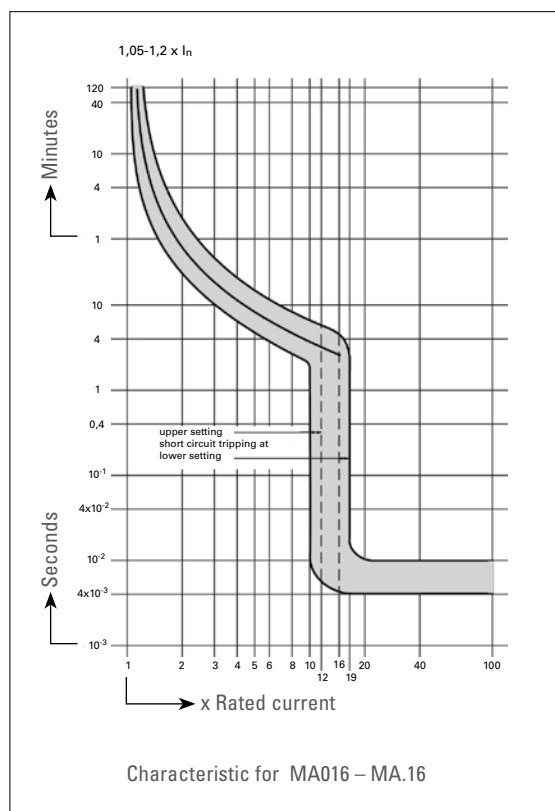

MOTOR PROTECTIVE CIRCUIT BREAKERS MA

Internal resistance per pole in mΩ and power loss in Watt of the complete device

TYPE	LOWER SETTING A	UPPER SETTING A	INTERNAL RESISTANCE PER POLE mΩ	POWER LOSS FOR THE COMPLETE DEVICE FOR	
				LOWER SETTING Watt	UPPER SETTING Watt
MA016M	0,10	0,16	85500	2,6	6,6
MA025M	0,16	0,25	35000	2,7	6,6
MA040M	0,25	0,40	15000	2,8	7,2
MA063M	0,40	0,63	5200	2,5	6,2
MA1.0M	0,63	1,0	2300	2,7	6,9
MA1.6M	1,0	1,6	950	2,9	7,3
MA2.5M	1,6	2,5	355	2,7	6,7
MA4.0M	2,5	4,0	142	2,7	6,8
MA6.3M	4,0	6,3	54	2,6	6,4
MA.10M	6,3	10	28	3,3	8,4
MA.16M	10	16	13,9	4,2	10,7
MA.20M	16	20	9,9	7,6	11,9
MA.25M	20	25	6,3	7,6	11,8
MA.32M	25	32	3,85	7,2	11,8
MA.40M	32	40	3,1	9,5	14,9

RATED CURRENTS (A)	RATED SHORT CIRCUIT WITHSTAND RATING I_{cu} ACCORDING TO IEC 60947-2. DIN EN 60947-2 I_{cu} (kA)			BACK-UP PROTECTION. IF THE SHORT CIRCUIT CURRENT EXCEEDS THE SHORT CIRCUIT WITHSTAND RATING BACK-UP FUSE (gL, aM) A WENN $I_{cc} > I_{cn}$		
	230 V	400 V	500 V	230 V	400 V	500 V

0,1 – 0,16	No additional protective devices needed inherently stable for any selected short circuit currents			No back-up fuse necessary inherently stable for any selected short circuit currents		
0,16 – 0,25						
0,25 – 0,4						
0,4 – 0,63						
0,63 – 1						
1 – 1,6						
1,6 – 2,5						
2,5 – 4				6		
4 – 6,3				6		
6,3 – 10				6		
10 – 16	10			6		
16 – 20	15	10	6	100	100	80
20 – 25	15	10	6	100	100	80
25 – 32	15	10	6	100	100	80
32 – 40	15	10	6	100	100	80

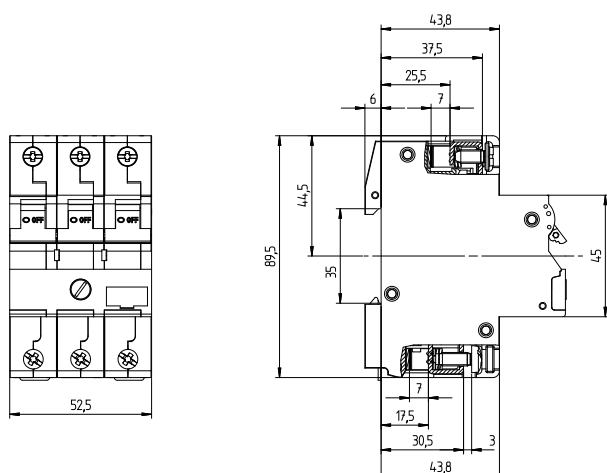

MOTOR PROTECTIVE CIRCUIT BREAKERS MS AND MA

Nominal rated motor currents

Nominal rated motor currents for three-phase motors (reference values for cage rotors)

Lowest possible short circuit fuse for three-phase motors. The maximum value is calculated according to setting range.

MOTOR POWER			230 V NOMINAL RATED MOTOR CURRENT	FUSE START-UP DIRECT	Y/Δ	400 V NOMINAL RATED MOTOR CURRENT	FUSE START-UP DIRECT	Y/Δ	500 V NOMINAL RATED MOTOR CURRENT	FUSE START-UP DIRECT	Y/Δ	690 V NOMINAL RATED MOTOR CURRENT	FUSE START-UP DIRECT	Y/Δ
kW	cos. φ	%	A	A	A	A	A	A	A	A	A	A	A	A
0,06	0,7	58	0,37	2	-	0,21	2	-	0,17	2	-	0,12	2	-
0,09	0,7	60	0,54	2	-	0,31	2	-	0,25	2	-	0,18	2	-
0,12	0,7	60	0,72	4	2	0,41	2	-	0,33	2	-	0,24	2	-
0,18	0,7	62	1,04	4	2	0,6	2	-	0,48	2	-	0,35	2	-
0,25	0,7	62	1,4	4	2	0,8	4	2	0,7	2	-	0,43	2	-
0,37	0,72	62	2	6	4	1,2	4	2	0,9	2	2	0,7	2	-
0,55	0,75	69	2,7	10	4	1,5	4	2	1,2	4	2	0,9	4	2
0,75	0,78	74	3,2	10	4	1,9	6	4	1,5	4	2	1,1	4	2
1,1	0,81	74	4,6	10	6	2,6	6	4	2,1	6	4	1,5	4	2
1,5	0,81	74	6,3	16	10	3,6	6	4	2,9	6	4	2,1	6	4
2,2	0,81	78	8,7	20	10	5	10	6	4	10	4	2,9	10	4
3	0,82	80	11,5	25	16	6,6	16	10	5,3	16	6	3,8	10	4
4	0,82	83	14,8	32	16	8,5	20	10	6,8	16	10	4,9	16	6
5,5	0,82	86	19,6	32	25	11,3	25	16	9	20	16	6,5	16	10
7,5	0,82	87	26,4	50	32	15,2	32	16	12,1	25	16	8,8	20	10
11	0,84	87	38	80	40	21,7	40	25	17,4	32	20	12,6	25	16
15	0,84	88	51	100	63	29,3	63	32	23,4	50	25	17	32	20
18,5	0,84	88	63	125	80	36	63	40	28,9	50	32	20,9	32	25
22	0,84	92	71	125	80	41	80	50	33	63	32	23,8	50	25
30	0,85	92	96	200	100	55	100	63	44	80	50	32	63	32
37	0,86	92	117	200	125	68	125	80	54	100	63	39	80	50
45	0,86	93	141	250	160	81	160	100	65	125	80	47	80	63
55	0,86	93	173	250	200	99	200	125	79	160	80	58	100	63
75	0,86	94	233	315	250	134	200	160	107	200	125	78	160	100
90	0,86	94	279	400	315	161	250	200	129	200	160	93	160	100
110	0,86	94	342	500	400	196	315	200	157	250	160	114	200	125
132	0,87	95	401	630	500	231	400	250	184	250	200	134	250	160
160	0,87	95	486	630	630	279	400	315	224	315	250	162	250	200
200	0,87	95	607	800	630	349	500	400	279	400	315	202	315	250
250	0,87	95	-	-	-	437	630	500	349	500	400	253	400	315
315	0,87	96	-	-	-	544	800	630	436	630	500	316	500	400
400	0,88	96	-	-	-	683	1000	800	547	800	630	396	630	400
450	0,88	96	-	-	-	769	1000	800	615	800	630	446	630	630
500	0,88	97	-	-	-	-	-	-	-	-	-	491	630	630
560	0,88	97	-	-	-	-	-	-	-	-	-	550	800	630
630	0,88	97	-	-	-	-	-	-	-	-	-	618	800	630

The nominal rated motor currents are valid for normal three-phase motors with surface and internal surface cooling with 1500 min⁻¹.

Start-up direct: Start-up current max. 6 x nominal rated motor current
Start-up time max. 5 s.

Y/Δ Start-up: Start-up current max. 2 x nominal rated motor current
Start-up time max. 15 s.
Set motor circuit breaker relays in a line to 0.58 x protective nominal rated motor current.

Nominal rated fuse currents for Y/Δ starts are also valid for three-phase motors with slip ring rotors.

Use larger fuses for a higher rated current, start-up current and / or a longer start-up time.

The table is valid for "delayed-action" or "gl" fuses (DIN VDE 0636)

For NH-fuses with aM characteristic, fuse = nominal rated current is selected.

ARTICLE NUMBER DIRECTORY

ARTICLE NO.	PAGE	ARTICLE NO.	PAGE	ARTICLE NO.	PAGE	ARTICLE NO.	PAGE
AMS110	109	B13T8	16	B25T8	16	B50DC2	28
AMS220	109	B13T9	18	B25T9	18	B50S1	12
AMS24	109	B16DC1	28	B2DC1	28	B50S2	13
AMS380	109	B16DC2	28	B2DC2	28	B50S3	13
AMS500	109	B16N8R	38	B2T1	16	B50S8	12
AMSD24	109	B16S1	12	B2T2	17	B50S9	14
AS100	73	B16S2	13	B2T3	17	B50T1	16
AS161	72	B16S3	13	B2T4	18	B50T2	17
AS63	73	B16S8	12	B2T8	16	B50T3	17
ASL161	72	B16S9	14	B2T9	18	B50T4	18
AVU1W	85	B16SL1	15	B32DC1	28	B50T8	16
AZ1TQ	95	B16SL3	15	B32DC2	28	B50T9	18
AZ1TS	95	B16T1	16	B32N8R	38	B5T1	16
AZ7TQ	95	B16T2	17	B32S1	12	B5T2	17
AZ7TS	95	B16T3	17	B32S2	13	B5T3	17
B100T1	35	B16T4	18	B32S3	13	B5T4	18
B100T2	35	B16T8	16	B32S8	12	B5T8	16
B100T3	35	B16T9	18	B32S9	14	B5T9	18
B100T4	35	B1DC1	28	B32T1	16	B63DC1	28
B10DC1	28	B1DC2	28	B32T2	17	B63DC2	28
B10DC2	28	B1T1	16	B32T3	17	B63S1	12
B10N8R	38	B1T2	17	B32T4	18	B63S2	13
B10S1	12	B1T3	17	B32T8	16	B63S3	13
B10S2	13	B1T4	18	B32T9	18	B63S8	12
B10S3	13	B1T8	16	B3DC1	28	B63S9	14
B10S8	12	B1T9	18	B3DC2	28	B63T1	16
B10S9	14	B20DC1	28	B3T1	16	B63T2	17
B10SL1	15	B20DC2	28	B3T2	17	B63T3	17
B10SL3	15	B20N8R	38	B3T3	17	B63T4	18
B10T1	16	B20S1	12	B3T4	18	B63T8	16
B10T1R	31	B20S2	13	B3T8	16	B63T9	18
B10T2	17	B20S3	13	B3T9	18	B6DC1	28
B10T3	17	B20S8	12	B40DC1	28	B6DC2	28
B10T4	18	B20S9	14	B40DC2	28	B6S1	12
B10T8	16	B20SL1	15	B40S1	12	B6S2	13
B10T9	18	B20SL3	15	B40S2	13	B6S3	13
B125T1	35	B20T1	16	B40S3	13	B6S8	12
B125T2	35	B20T2	17	B40S8	12	B6S9	14
B125T3	35	B20T3	17	B40S9	14	B6SL1	15
B125T4	35	B20T4	18	B40T1	16	B6SL3	15
B13DC1	28	B20T8	16	B40T2	17	B6T1	16
B13DC2	28	B20T9	18	B40T3	17	B6T2	17
B13N8R	38	B25DC1	28	B40T4	18	B6T3	17
B13S1	12	B25DC2	28	B40T8	16	B6T4	18
B13S2	13	B25N8R	38	B40T9	18	B6T8	16
B13S3	13	B25S1	12	B4DC1	28	B6T9	18
B13S8	12	B25S2	13	B4DC2	28	B80T1	35
B13S9	14	B25S3	13	B4T1	16	B80T2	35
B13SL1	15	B25S8	12	B4T2	17	B80T3	35
B13SL3	15	B25S9	14	B4T3	17	B80T4	35
B13T1	16	B25T1	16	B4T4	18	BS063	103
B13T2	17	B25T2	17	B4T8	16	BS1	103
B13T3	17	B25T3	17	B4T9	18	BS1.6	103
B13T4	18	B25T4	18	B50DC1	28	BS10	103

ARTICLE NUMBER DIRECTORY

ARTICLE NO.	PAGE	ARTICLE NO.	PAGE	ARTICLE NO.	PAGE	ARTICLE NO.	PAGE
BS16	103	C125T2	35	C20DC1	28	C32S3	13
BS2.5	103	C125T3	35	C20DC2	28	C32S8	12
BS20	103	C125T4	35	C20N8R	38	C32S9	14
BS25	103	C13DC1	28	C20S1	12	C32T1	16
BS32	103	C13DC2	28	C20S2	13	C32T2	17
BS4	103	C13N8R	38	C20S3	13	C32T3	17
BS6.3	103	C13S1	12	C20S8	12	C32T4	18
C0.3T1	16	C13S2	13	C20S9	14	C32T8	16
C0.3T2	17	C13S3	13	C20SL1	15	C32T9	18
C0.3T3	17	C13S8	12	C20SL3	15	C3DC1	28
C0.3T4	18	C13S9	14	C20T1	16	C3DC2	28
C0.3T8	16	C13SL1	15	C20T2	17	C3S1	12
C0.3T9	18	C13SL3	15	C20T3	17	C3S2	13
C0.5DC1	28	C13T1	16	C20T4	18	C3S3	13
C0.5DC2	28	C13T2	17	C20T8	16	C3S8	12
C0.5T1	16	C13T3	17	C20T9	18	C3S9	14
C0.5T2	17	C13T4	18	C25DC1	28	C3T1	16
C0.5T3	17	C13T8	16	C25DC2	28	C3T2	17
C0.5T4	18	C13T9	18	C25N8R	38	C3T3	17
C0.5T8	16	C16DC1	28	C25S1	12	C3T4	18
C0.5T9	18	C16DC2	28	C25S2	13	C3T8	16
C0.8T1	16	C16N8R	38	C25S3	13	C3T9	18
C0.8T2	17	C16S1	12	C25S8	12	C40DC1	28
C0.8T3	17	C16S2	13	C25S9	14	C40DC2	28
C0.8T4	18	C16S3	13	C25T1	16	C40S1	12
C0.8T8	16	C16S8	12	C25T2	17	C40S2	13
C0.8T9	18	C16S9	14	C25T3	17	C40S3	13
C1.6T1	16	C16SL1	15	C25T4	18	C40S8	12
C1.6T2	17	C16SL3	15	C25T8	16	C40S9	14
C1.6T3	17	C16T1	16	C25T9	18	C40T1	16
C1.6T4	18	C16T2	17	C2DC1	28	C40T2	17
C1.6T8	16	C16T3	17	C2DC2	28	C40T3	17
C1.6T9	18	C16T4	18	C2S1	12	C40T4	18
C100T1	35	C16T8	16	C2S2	13	C40T8	16
C100T2	35	C16T9	18	C2S3	13	C40T9	18
C100T3	35	C1DC1	28	C2S8	12	C4DC1	28
C100T4	35	C1DC2	28	C2S9	14	C4DC2	28
C10DC1	28	C1S1	12	C2T1	16	C4S1	12
C10DC2	28	C1S2	13	C2T2	17	C4S2	13
C10N8R	38	C1S3	13	C2T3	17	C4S3	13
C10S1	12	C1S8	12	C2T4	18	C4S8	12
C10S2	13	C1S9	14	C2T8	16	C4S9	14
C10S3	13	C1T1	16	C2T9	18	C4T1	16
C10S8	12	C1T2	17	C3.5T1	16	C4T2	17
C10S9	14	C1T3	17	C3.5T2	17	C4T3	17
C10SL1	15	C1T4	18	C3.5T3	17	C4T4	18
C10SL3	15	C1T8	16	C3.5T4	18	C4T8	16
C10T1	16	C1T9	18	C3.5T8	16	C4T9	18
C10T2	17	C2.5T1	16	C3.5T9	18	C50DC1	28
C10T3	17	C2.5T2	17	C32DC1	28	C50DC2	28
C10T4	18	C2.5T3	17	C32DC2	28	C50S1	12
C10T8	16	C2.5T4	18	C32N8R	38	C50S2	13
C10T9	18	C2.5T8	16	C32S1	12	C50S3	13
C125T1	35	C2.5T9	18	C32S2	13	C50S8	12

ARTICLE NUMBER DIRECTORY

ARTICLE NO.	PAGE
C50S9	14
C50T1	16
C50T2	17
C50T3	17
C50T4	18
C50T8	16
C50T9	18
C5S1	12
C5S2	13
C5S3	13
C5S8	12
C5S9	14
C5T1	16
C5T2	17
C5T3	17
C5T4	18
C5T8	16
C5T9	18
C63DC1	28
C63DC2	28
C63S1	12
C63S2	13
C63S3	13
C63S8	12
C63S9	14
C63T1	16
C63T2	17
C63T3	17
C63T4	18
C63T8	16
C63T9	18
C6DC1	28
C6DC2	28
C6S1	12
C6S2	13
C6S3	13
C6S8	12
C6S9	14
C6SL1	15
C6SL3	15
C6T1	16
C6T2	17
C6T3	17
C6T4	18
C6T8	16
C6T9	18
C80T1	35
C80T2	35
C80T3	35
C80T4	35
C8T1	16
C8T2	17
C8T3	17
C8T4	18

ARTICLE NO.	PAGE
C8T8	16
C8T9	18
D0.3T1	16
D0.3T2	17
D0.3T3	17
D0.3T4	18
D0.3T8	16
D0.3T9	18
D0.5T1	16
D0.5T2	17
D0.5T3	17
D0.5T4	18
D0.5T8	16
D0.5T9	18
D0.8T1	16
D0.8T2	17
D0.8T3	17
D0.8T4	18
D0.8T8	16
D0.8T9	18
D1.6T1	16
D1.6T2	17
D1.6T3	17
D1.6T4	18
D1.6T8	16
D1.6T9	18
D100T1	35
D100T2	35
D100T3	35
D100T4	35
D10T1	16
D10T2	17
D10T3	17
D10T4	18
D10T8	16
D10T9	18
D125T1	35
D125T2	35
D125T3	35
D125T4	35
D13T1	16
D13T2	17
D13T3	17
D13T4	18
D13T8	16
D13T9	18
D16T1	16
D16T2	17
D16T3	17
D16T4	18
D16T8	16
D16T9	18
D1T1	16
D1T2	17

ARTICLE NO.	PAGE
D1T3	17
D1T4	18
D1T8	16
D1T9	18
D2.5T1	16
D2.5T2	17
D2.5T3	17
D2.5T4	18
D2.5T8	16
D2.5T9	18
D20T1	16
D20T2	17
D20T3	17
D20T4	18
D20T8	16
D20T9	18
D25T1	16
D25T2	17
D25T3	17
D25T4	18
D25T8	16
D25T9	18
D2T1	16
D2T2	17
D2T3	17
D2T4	18
D2T8	16
D2T9	18
D3.5T1	16
D3.5T2	17
D3.5T3	17
D3.5T4	18
D3.5T8	16
D3.5T9	18
D32T1	16
D32T2	17
D32T3	17
D32T4	18
D32T8	16
D32T9	18
D3T1	16
D3T2	17
D3T3	17
D3T4	18
D3T8	16
D3T9	18
D40T1	16
D40T2	17
D40T3	17
D40T4	18
D40T8	16
D40T9	18
D4T1	16
D4T2	17

ARTICLE NO.	PAGE
D4T3	17
D4T4	18
D4T8	16
D4T9	18
D50T1 *	16
D50T2 *	17
D50T3 *	17
D50T4 *	18
D50T8 *	16
D50T9 *	18
D5T1	16
D5T2	17
D5T3	17
D5T4	18
D5T8	16
D5T9	18
D63T1 *	16
D63T2 *	17
D63T3 *	17
D63T4 *	18
D63T8 *	16
D63T9 *	18
D6T1	16
D6T2	17
D6T3	17
D6T4	18
D6T8	16
D6T9	18
D80T1	35
D80T2	35
D80T3	35
D80T4	35
D8T1	16
D8T2	17
D8T3	17
D8T4	18
D8T8	16
D8T9	18
DS2301W	84
DZ201	96
DZ302	96
EASS	31
EASS	118
FA110UM	118
FA12UM	118
FA24UM	118
FA48UM	118
FHMS01	108
FHMS10	108
FHMS11	108
FL110	31
FL12	31
FL24	31
FL48	31

ARTICLE NUMBER DIRECTORY

ARTICLE NO.	PAGE	ARTICLE NO.	PAGE	ARTICLE NO.	PAGE	ARTICLE NO.	PAGE
FS01210	78	K0.3T1	16	K20T1	16	K5T1	16
FS23010	78	K0.3T2	17	K20T2	17	K5T2	17
FS23011	78	K0.3T3	17	K20T3	17	K5T3	17
FS23020	78	K0.3T4	18	K20T4	18	K5T4	18
FZU20	80	K0.3T8	16	K20T8	16	K5T8	16
G31006	34	K0.3T9	18	K20T9	18	K5T9	18
G31009	34	K0.5T1	16	K25T1	16	K63T1	16
G31011S	34	K0.5T2	17	K25T2	17	K63T2	17
G31012	34	K0.5T3	17	K25T3	17	K63T3	17
G31606	34	K0.5T4	18	K25T4	18	K63T4	18
G31609	34	K0.5T8	16	K25T8	16	K63T8	16
G31611	34	K0.5T9	18	K25T9	18	K63T9	18
G31611S	34	K0.8T1	16	K2T1	16	K6T1	16
G31612	34	K0.8T2	17	K2T2	17	K6T2	17
G41606	66	K0.8T3	17	K2T3	17	K6T3	17
GS161	72	K0.8T4	18	K2T4	18	K6T4	18
H10UM	119	K0.8T8	16	K2T8	16	K6T8	16
H11UM	119	K0.8T9	18	K2T9	18	K6T9	18
H12UM	119	K1.6T1	16	K3.5T1	16	K8T1	16
H21UM	119	K1.6T2	17	K3.5T2	17	K8T2	17
HDS	118	K1.6T3	17	K3.5T3	17	K8T3	17
HL10	32	K1.6T4	18	K3.5T4	18	K8T4	18
HL11	32	K1.6T8	16	K3.5T8	16	K8T8	16
HL11L*	32	K1.6T9	18	K3.5T9	18	K8T9	18
HL12	32	K10T1	16	K32T1	16	KT08	97
HL21	32	K10T2	17	K32T2	17	KT16	97
HMS01	107	K10T3	17	K32T3	17	KT24	97
HMS02	107	K10T4	18	K32T4	18	LOM5521	98
HMS10	107	K10T8	16	K32T8	16	LOM8522	98
HMS11	107	K10T9	18	K32T9	18	LOMD112	99
HMS20	107	K13T1	16	K3T1	16	LOMD212	99
HSL10	32	K13T2	17	K3T2	17	LOMK218	99
HSL11	32	K13T3	17	K3T3	17	LOMK330	99
HSL11L*	32	K13T4	18	K3T4	18	LOMK430	99
HWL10	32	K13T8	16	K3T8	16	LOMW100	99
HWL10PK	37	K13T9	18	K3T9	18	LRU39	83
HWL20	32	K16T1	16	K40T1	16	MA016M	117
HWL20PK	37	K16T2	17	K40T2	17	MA025M	117
IR01210	74	K16T3	17	K40T3	17	MA040M	117
IR23010	74	K16T4	18	K40T4	18	MA063M	117
IR23011	74	K16T8	16	K40T8	16	MA1.0M	117
IR23020	74	K16T9	18	K40T9	18	MA1.6M	117
IS2011	89	K1T1	16	K4T1	16	MA10M	117
IS2020	89	K1T2	17	K4T2	17	MA16M	117
IS2522	89	K1T3	17	K4T3	17	MA2.5M	117
IS2531	89	K1T4	18	K4T4	18	MA20M	117
IS2540	89	K1T8	16	K4T8	16	MA25M	117
IS4040	89	K1T9	18	K4T9	18	MA32M	117
IS6340	89	K2.5T1	16	K50T1	16	MA4.0M	117
ISD	31	K2.5T2	17	K50T2	17	MA40M	117
ISD	89	K2.5T3	17	K50T3	17	MA6.3M	117
ISH11	89	K2.5T4	18	K50T4	18	MRU1W	85
ISP2	89	K2.5T8	16	K50T8	16	MS.BS	111
ISP3	89	K2.5T9	18	K50T9	18	MS.C21	110

ARTICLE NUMBER DIRECTORY

ARTICLE NO.	PAGE	ARTICLE NO.	PAGE	ARTICLE NO.	PAGE	ARTICLE NO.	PAGE
MS.C31	110	MST4	104	RB1601	65	RC4003	65
MS.C41	110	MST6.3	104	RB1603	65	RC4010	65
MS.C51	110	MSW1	105	RB1603N	65	RC4030	65
MS.F41	110	MSW1.6	105	RB1610	65	RC4050	65
MS.F55	110	MSW10	105	RB1630	65	RH11	53
MS.G41	110	MSW16	105	RB1650	65	RLH1W	66
MS.G55	110	MSW2.5	105	RB2001	65	RP2101	47
MS.N	111	MSW20	105	RB2003	65	RP2203	47
MS.P51	110	MSW4	105	RB2010	65	RP2230	47
MS.PS2	111	MSW6.3	105	RB2030	65	RP2303	47
MS.PT	111	MSWC2.5	106	RB2050	65	RP2330	47
MS.PV	111	MSWC4	106	RB2501	65	RP2403	47
MS.SLG2	111	MSWC6.3	106	RB2503	65	RP2430	47
MS.SLG3	111	MWC10	106	RB2510	65	RP2450	47
MS.SLJ2	111	NW1	88	RB2530	65	RP4203	47
MS.SLJ3	111	NW2	88	RB2550	65	RP4203L	47
MS.SLR2	111	NWA1	88	RB3203	65	RP4230	47
MS.SLR3	111	NWA2	88	RB3210	65	RP4230L	47
MS.SLW2	111	RA4203	51	RB3230	65	RP4250	47
MS.SLW3	111	RA4230	51	RB3250	65	RP4250L	47
MS.VS	111	RA4250	51	RB4003	65	RP4303	47
MS016	103	RA4303	51	RB4010	65	RP4303K	48
MS025	103	RA4330	51	RB4030	65	RP4303L	47
MS04	103	RA4330S	52	RB4050	65	RP4330	47
MS063	103	RA4350	51	RC0601	65	RP4330L	47
MS1	103	RA4403	51	RC0603	65	RP4330S	48
MS1.6	103	RA4430	51	RC0610	65	RP4350	47
MS10	103	RA4430S	52	RC0630	65	RP4350L	47
MS16	103	RA4450	51	RC0650	65	RP4403	47
MS2.5	103	RA4503	51	RC1001	65	RP4403K	48
MS20	103	RA4530	51	RC1003	65	RP4403L	47
MS25	103	RA4530S	52	RC1010	65	RP4430	47
MS32	103	RA4550	51	RC1030	65	RP4430L	47
MS4	103	RA4603	51	RC1050	65	RP4430S	48
MS6.3	103	RA4630	51	RC1601	65	RP4450	47
MSH1	105	RA4630S	52	RC1603	65	RP4450L	47
MSH1.6	105	RA4650	51	RC1603N	65	RP4503	47
MSH10	105	RA4703	51	RC1610	65	RP4530	47
MSH16	105	RA4730	51	RC1630	65	RP4550	47
MSH2.5	105	RA4730S	52	RC1650	65	RP4603	47
MSH20	105	RA4750	51	RC2001	65	RP4630	47
MSH4	105	RB0601	65	RC2003	65	RP4630S	48
MSH6.3	105	RB0603	65	RC2010	65	RP4650	47
MST016	104	RB0610	65	RC2030	65	RP4703	47
MST025	104	RB0630	65	RC2050	65	RP4730	47
MST04	104	RB0650	65	RC2501	65	RP4730S	48
MST063	104	RB1001	65	RC2503	65	RP4750	47
MST1	104	RB1003	65	RC2510	65	RSB230	73
MST1.6	104	RB1003N	65	RC2530	65	RSG230	73
MST10	104	RB1010	65	RC2550	65	RSR230	73
MST16	104	RB1030	65	RC3203	65	RST230	73
MST2.5	104	RB1050	65	RC3210	65	RSY230	73
MST20	104	RB1303	65	RC3230	65	RVU1W	85
MST25	104	RB1303N	65	RC3250	65	RW2103	43

ARTICLE NUMBER DIRECTORY

ARTICLE NO.	PAGE
-------------	------

RW2110	43
RW2130	43
RW2203	43
RW2210	43
RW2230	43
RW2303	43
RW2310	43
RW2330	43
RW2403	43
RW2410	43
RW2430	43
RW4103	44
RW4110	44
RW4130	44
RW4203	44
RW4210	44
RW4230	44
RW4303	44
RW4303K	45
RW4310	44
RW4330	44
RW4330S	45
RW4403	44
RW4403K	45
RW4410	44
RW4430	44
RW4430S	45
RW4503	44
RW4530	44
RW4550	44
RW4603	44
RW4610	44
RW4630	44
RW4630S	45
RW4703	44
RW4710	44
RW4730	44
RW4730S	45
RW4750	44
SB.A1	33
SB.A2	33
SB.A3	33
SB.A5	33
SB.D02	112
SB.D03	112
SB.D04	112
SB.D12	112
SB.D13	112
SB.D14	112
SB.D15	112
SB.D22	112
SB.D24	112
SB.DA1	112
SB.DE1	112

ARTICLE NO.	PAGE
-------------	------

SB16010	33
SB26010	33
SB26010	66
SB26016	66
SB26216	33
SB26216	66
SB31210	33
SB31210	118
SB36010	33
SB36010	118
SB36016	33
SB36016	118
SB36316	33
SB36316	118
SB41618	66
SB41627	33
SB41627	66
SB46016	33
SBL1N	39
SBMS32	107
SBN1N	39
SD230	73
SDO.124	33
SDO.316	33
SHMS01	108
SHMS10	108
SN11012	39
SN11054	39
SN31612	39
SN31654	39
SP2301W	74
ST40	97
ST63	97
STU1W	76
STU2W	76
TDU500	82
TZA2301	93
UA110M	118
UA220M	118
UA240M	118
UA24M	118
UA380M	118
UA415M	118
UL230	31
UMS110	109
UMS220	109
UMS24	109
UMS380	109
UMS500	109
VHMS11	107
VHMS20	107
WS161	72
WT161	73
Z0.3T1	16

ARTICLE NO.	PAGE
-------------	------

Z0.3T2	17
Z0.3T3	17
Z0.5T1	16
Z0.5T2	17
Z0.5T3	17
Z0.8T1	16
Z0.8T2	17
Z0.8T3	17
Z1.6T1	16
Z1.6T2	17
Z1.6T3	17
Z10T1	16
Z10T2	17
Z10T3	17
Z13T1	16
Z13T2	17
Z13T3	17
Z16T1	16
Z16T2	17
Z16T3	17
Z1T1	16
Z1T2	17
Z1T3	17
Z2.5T1	16
Z2.5T2	17
Z2.5T3	17
Z20T1	16
Z20T2	17
Z20T3	17
Z25T1	16
Z25T2	17
Z25T3	17
Z2T1	16
Z2T2	17
Z2T3	17
Z3.5T1	16
Z3.5T2	17
Z3.5T3	17
Z32T1	16
Z32T2	17
Z32T3	17
Z3T1	16
Z3T2	17
Z3T3	17
Z4T1	16
Z4T2	17
Z4T3	17
Z5T1	16
Z5T2	17
Z5T3	17
Z6T1	16
Z6T2	17
Z6T3	17
Z8T1	16

ARTICLE NO.	PAGE
-------------	------

Z8T2	17
Z8T3	17

Complete product system
Extensive range of applications
Quality made in Germany

Worldwide leadership in
connecting and protecting power –
for over 90 years

ABL SURSUM

Bayerische Elektrozubehör GmbH & Co. KG

Ottensooser Straße 22
91207 Lauf / Pegnitz

Postfach 10 02 47
91192 Lauf / Pegnitz

Telefon +49 (0) 9123 188-0
Telefax +49 (0) 9123 188-188

info@abl-sursum.com
www.abl-sursum.com